

SERVICE MANUAL

A-2300SD

STEREO TAPE DECK

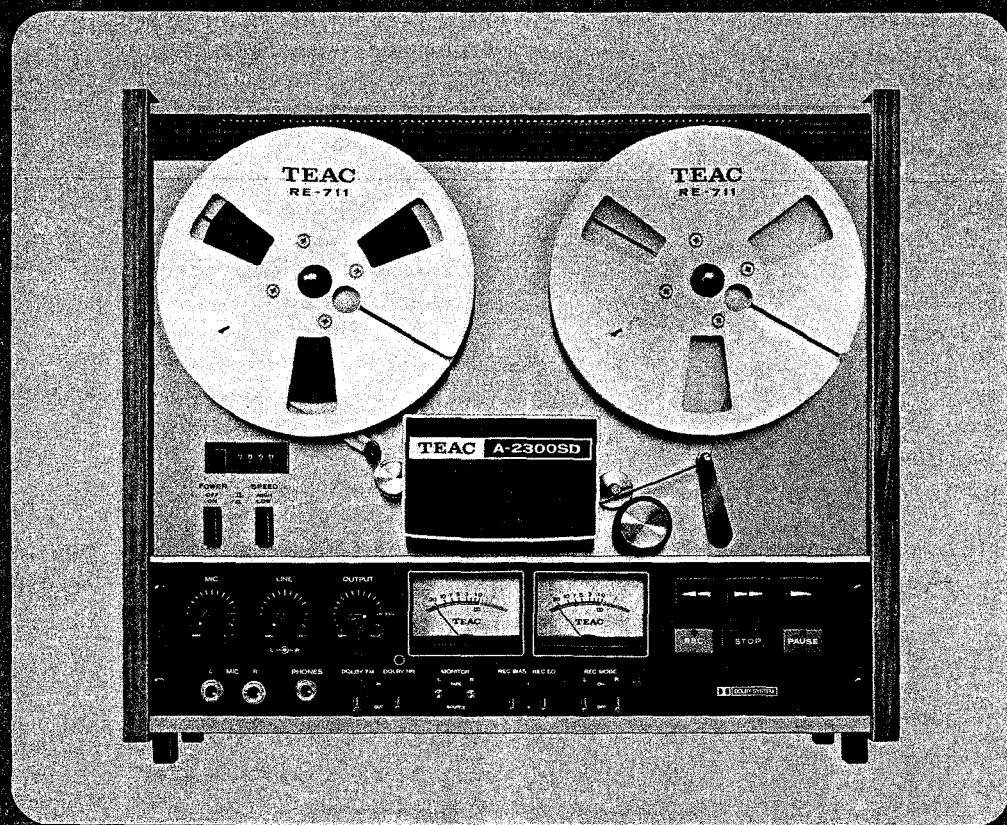

TEAC
TOKYO, JAPAN

—CONTENTS—

1. General Description	3	9. Measurement and Adjustment	14 ~ 19
2. Service Data	4	—Electrical—	
3. Tools for Testing and Maintenance	5	9-1 Adjustment Locations	
4. Partial Disassembly	6 ~ 7	9-2 Adjustment Sequence	
4-1 Removing Wooden Sides and Rear Panel		9-3 Power Supply Check and Adj.	
4-2 Head Assembly Removal		9-4 Playback Head Azimuth Adj.	
4-3 Removal of Capstan Motor		9-5 Specified Output level Setting	
4-4 Removal of capstan Assembly		9-6 VU Meter Level Set	
4-5 Removal of Reel Motor		9-7 Frequency Response —Playback—	
4-6 Removal of Tension Arms		9-8 Phones Output Check	
5. Tape Transport Parts Location	8	9-9 Monitor Level Setting	
5-1 TEAC Maintenance Fluids		9-10 Specified Input Level Setting	
6. Head Replacement and Alignment	9	9-11 VU Meter Check	
6-1 Head Replacement		9-12 CAL TONE Level Adj.	
6-2 Head Adj. Screws and Head Wiring		9-13 MIC Input Level Check	
6-3 Head Alignment		9-14 MPX Filter Response Check	
6-4 Mis -Alignment of the Head		9-15 Bias Trap Adj.	
—Example —		9-16 Bias Leakage Check	
7. Measurement and Adjustment	10 ~ 12	9-17 Record Head Azimuth Adj.	
—Mechanical—		9-18 Bias Adj.	
7-1 Pinch Roller Pressure		9-19 Rec EQ #1 Level Set	
7-2 Brake Torque		9-20 Overall Frequency Response	
7-3 Back Tension		9-21 Rec Bias #2 Frequency Response Check	
7-4 Take-up Torque		9-22 Rec EQ #2 Level Set	
7-5 Reel Height Adjustment		9-23 Monophonic Recording	
7-6 Tape Speed		9-24 Signal-To-Noise Ratio (Playback)	
7-7 Flutter		9-25 Signal-To-Noise Ratio (Overall)	
7-8 Voltage and Frequency Conversion		9-26 Track-To-Track Cross Talk Rejection	
8. Simplified Diagram	13	9-27 Channel-To-Channel Cross Talk Rejection	
and Level Diagrams		9-28 Optimum Erasure Measurement	
		9-29 Dolby Encoder Check (Playback)	
		9-30 Dolby Decoder Check	
		9-31 Dolby NR Check	
		10. Trouble Shooting	20
		*11. Exploded Views and Parts List	24 ~ 30
		*12. PC Board Section	32 ~ 34
		* For more detailed contents of Parts List, see page 22.	

1. GENERAL DESCRIPTION

This TEAC A-2300SD open reel tape deck was manufactured with pride by the craftsmen of TEAC Corporation. It contains all of the features which made the earlier A-2300 one of the most popular open reel tape decks ever sold. In addition, the A-2300SD has built-in Dolby* noise reduction circuitry for the extra advantages of virtually hiss-free tape dubbing. This circuitry includes the Dolby "B" Noise reduction system, FM/COPY function with new 50 μ sec compensation, CAL TONE oscillator and MPX filter system.

The TEAC A-2300 has achieved an enviable reputation for quality since its introduction in the market. During this period many design improvements and modifications have been incorporated. However, the recent introduction of more versatile, improved tape products called for extensive modification and redesign in order to provide proper utilization of these tapes. Therefore we have produced the New A-2300SD, to provide complete flexibility in selection of recording tapes and to provide state of the art quality in your deck.

The basic design of the A-2300SD is highly similar to that of the A-2300S. Therefore much of the information in this Service manual may be applied to the A-2300S also.

* "DOLBY" and the double D symbol  are trade marks of Dolby Laboratories, Inc.

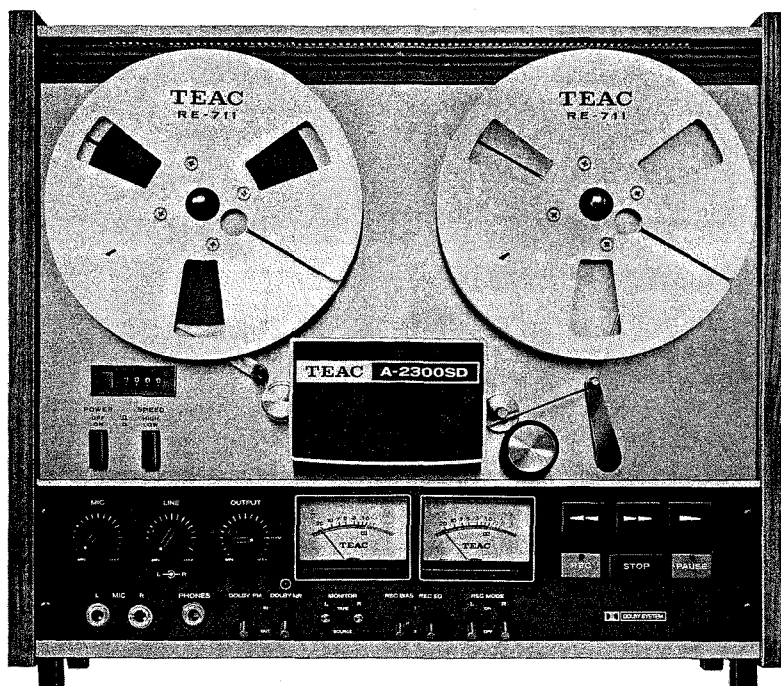

2. SERVICE DATA

Track System	1/4 Track 2 Channel stereophonic 1/4 Track 1 Channel monophonic
Heads	Three: Erase, Record and Playback
Reel Size	7" and 5"
Tape Speed	7-1/2 ips (19 cm/s), 3-3/4 ips (9.5 cm/s)
Motors	Two 6-pole eddy current motors for reel drive 4/8 pole hysteresis synchronous capstan motor
Wow and Flutter (playback)	0.08% (WRMS) at 7-1/2 ips 0.10% (WRMS) at 3-3/4 ips
Frequency Response	Refer to Frequency Response Limits chart
Signal-to-noise Ratio (overall unweighted)	50 dB or higher; Improved up to 5 dB at 1 kHz, 10 dB over 5 kHz with Dolby NR
Rewind/Fast Forward Time	140 seconds or less with 1800 foot tape
Inputs	Line: 308 mV (-8 dB)/50k Ohms Microphone: 774 mV (-60 dB)/30k Ohms
Outputs	Line: 0.775 V (0 dB)/50k Ohms Headphone: 49 mV (-24 dB ±2 dB)/8 Ohms
Bias Frequency	100 kHz ±5 kHz (push-pull oscillator)
Crosstalk Rejection	35 dB or more, adjacent track at 125 Hz
Channel Separation	45 dB or more, channel to channel at 1 kHz
Erase Efficiency	68 dB or more
Operating Position	Horizontal or Vertical
Power Requirement	117 V AC 60Hz 95 W (USA/Canada model)
Weight	39 lbs (18 kg) net
Dimensions	17-5/16" (W) x 15-7/16" (H) x 8-5/16" (D)

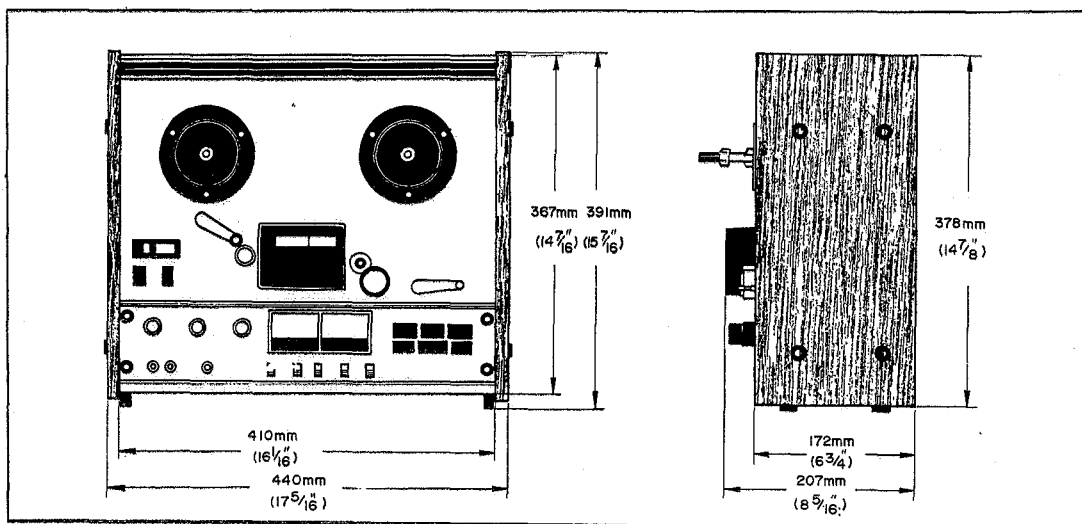

Fig. 2-2 Dimensions

3. TOOLS FOR TESTING AND MAINTENANCE

A minimum of the following tools and test instruments are required for measuring and adjusting to obtain optimum performance. Regular maintenance tools will be adequate for those not listed here. If any test instrument listed here is not available, a close equivalent can be used.

- SPRING SCALE 0–4kg (0–8 lbs)
0–300g (0–10 oz)
- FLUTTER METER. . . Meguro Denpa Co., Model MK-668A
or D & R Co., Model FL-4B
- DIGITAL COUNTER . Range; 0 Hz–100 kHz
- BANDPASS FILTER . TEAC Model M-206A (1 kHz)
- VTVM (AC) Hewlett-Packard Co., Model 400E
- OSCILLOSCOPE General purpose
- BLANK TAPE TEAC YTT-8013 and YTT-8003
- TEAC TEST TAPE . . YTT-1002 (3-3/4 ips), YTT-1003
(7-1/2 ips) for Playback Alignment
Test
YTT-2002 (3-3/4 ips), YTT-2003
(7-1/2 ips) for Tape Speed and
wow Flutter Test
- TEAC EMPTY REEL RE-702 (2" hub)
RE-701 (4" hub)
- TOOLS General
2 mm nut driver
Hex head Allen Wrench
Non-inductive driver
- DEMAGNETIZER . . TEAC E-3 or equivalent

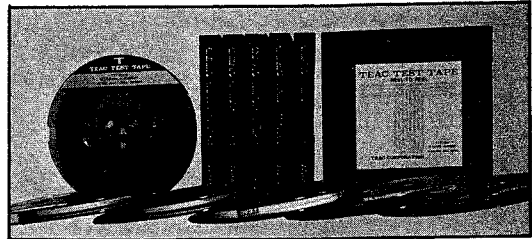

Fig. 3-1 TEAC Test Tape

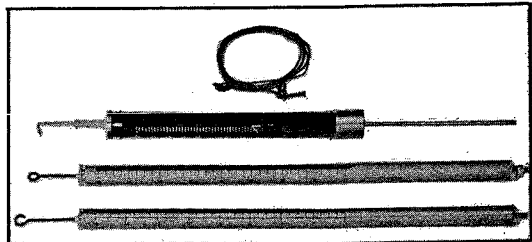

Fig. 3-2 Spring Scale

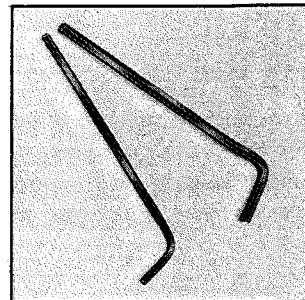

Fig. 3-3 Hex head (Allen) Wrench

Recommended tape and BIAS/EQ settings

If the TEAC YTT-series blank test tapes (8013, 8003) are not available use any of the tapes listed below that require the same EQ switch and BIAS switch settings.

Recommended BIAS and EQ switch settings for various types of tape

1 mil TAPES (for 2/4 track model)	Switch positions	
	BIAS	EQ
MAXELL UD-35 FUJI-FILM FG-150 SONY SLH Series	1	1
FUJI-FILM FB-151 TDK SD-150 BASF LP-35LH MEMOREX 1800	2	1
SCOTCH 207 AGFA-GEVAERT PE-36	1	2

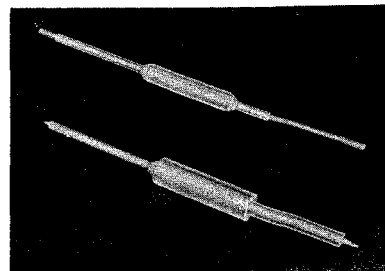

Fig. 3-4 Non-inductive driver

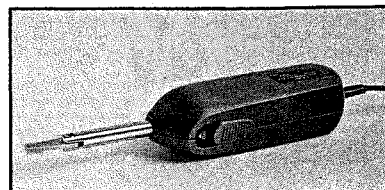

Fig. 3-5 TEAC E-3
Head Demagnetizer

4. PARTIAL DISASSEMBLY

4-1 REMOVING WOODEN SIDES AND REAR PANEL

See illustration for complete disassembly instructions. Most amplifier checks and adjustments can be made from the bottom with the (bottom) panel removed.

These adjustments should be performed by experienced technicians, and then only when going through the complete test and check procedures on the unit which is being tested.

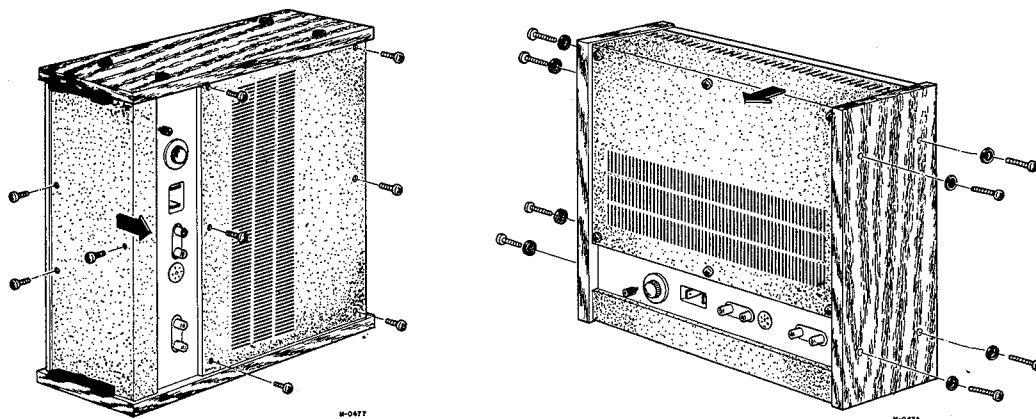

Fig. 4-1 Removing Wooden sides and Rear panel

4-2 HEAD ASSEMBLY REMOVAL

To change the head assembly as a unit, remove the 2 mounting screws. Note the positions of the wires on the circuit board before unsoldering. Unsolder the wires. Solder wires of the new assembly in exactly the same positions.

4-3 REMOVAL OF CAPSTAN MOTOR

1. Remove the 3 screws (a) holding the capstan motor plate.
2. Remove PC Board with C5 by removing 2 screws (b).
3. Unsolder the 6 wires connecting the capstan motor.
4. Remove the 4 screws holding the capstan motor to the motor plate. Watch for the Rubber Cushions.
5. Loosen the 2 set screws (hex head) in pulley and lift off pulley.

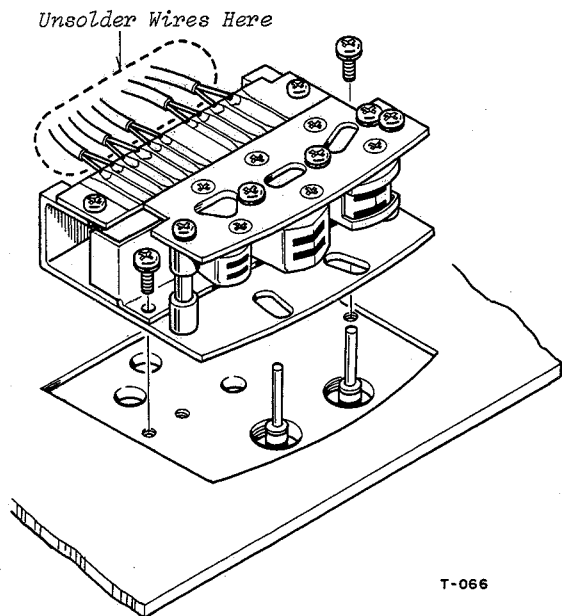

Fig. 4-2 Head Ass'y Removal

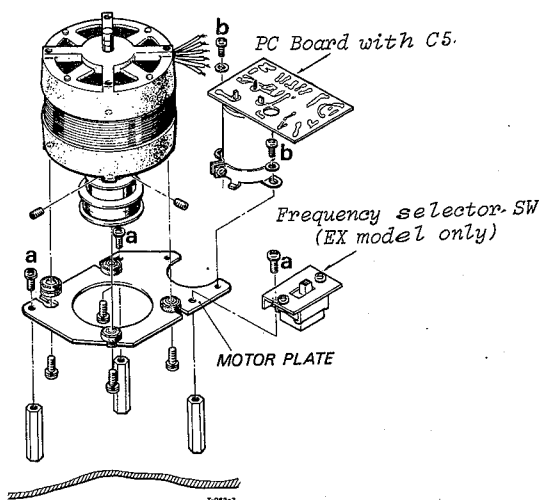

Fig. 4-3 Capstan Motor Removal

4-4 REMOVAL OF CAPSTAN ASSEMBLY

1. Unscrew dust cap (front panel).
2. Remove 2 screws from rear bracket, allow bracket to drop toward floor of case.
3. Remove capstan belt.
4. Loosen 2 screws in flywheel. Remove flywheel.
5. Remove 3 screws in capstan ass'y.
6. Gently move capstan ass'y up and down until it slides out of panel.

NOTE: A clearance of 0.01" must be maintained between the flywheel and the capstan ass'y.

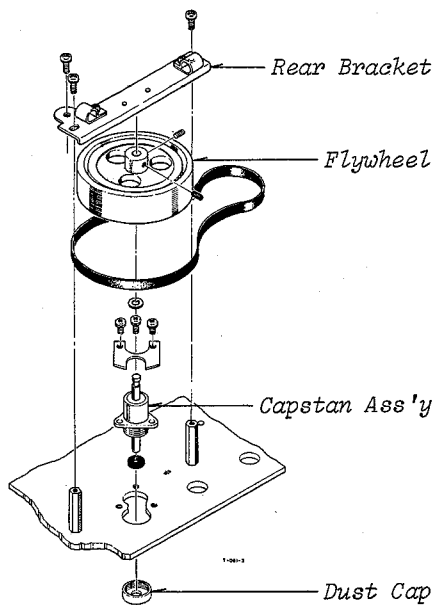

Fig. 4-4 Capstan Ass'y Removal

4-5 REMOVAL OF REEL MOTOR

1. Loosen 2 hex screws in brake drum, lift off brake drum.
2. Remove 4 screws securing the brake ass'y to the motor.
3. Remove reel table ass'y, remove 4 screws securing motor to front panel.

NOTE: Reel motor are mirror images of each other. These motors are not interchangeable.

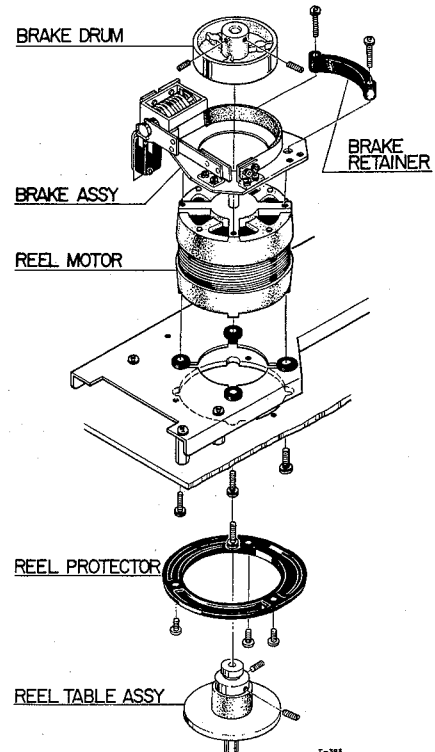

Fig. 4-5 Reel Motor Removal

4-6 REMOVAL OF TENSION ARMS LEFT AND RIGHT

See illustration for complete disassembly instructions.

IMPORTANT: After reassembly check clearance to ascertain that arm moves freely and is not binding.

CAUTION: Do not over-tighten screws holding micro-switches.

Insulating spacer and micro-switches are easily broken by excess pressure.

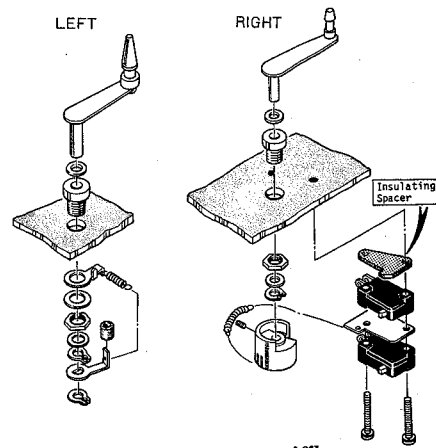
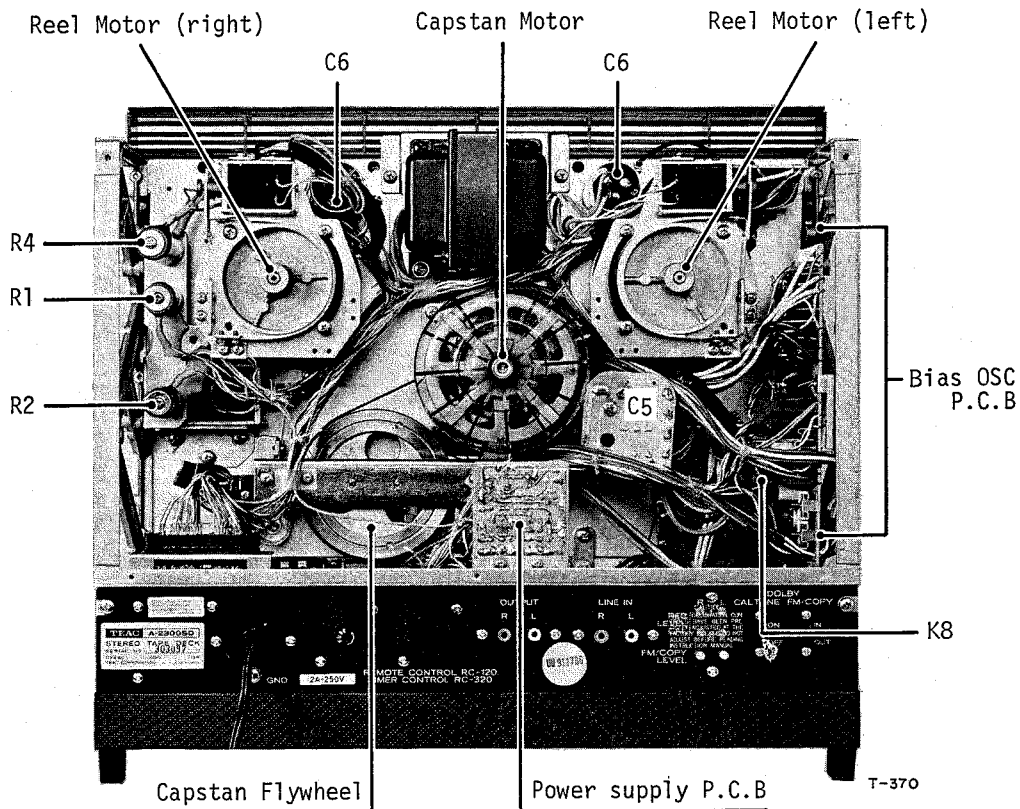

Fig. 4-6 Tension Arms Removal

5. TAPE TRANSPORT PARTS LOCATION

-REAR VIEW-



NOTE: R4, R1 and R2 are adjustable resistors which are used to adjust back tension for fast forward mode, take-up torque and back tension, respectively, Refer to page 11 TORQUE MEASUREMENT procedure sections.

5-1 TEAC MAINTENANCE FLUIDS

-CLEANING-

To prevent the loss of high-frequency response, insufficient erase or tape squeal, the heads should be cleaned frequently. Under average operating conditions, clean the heads after each 8 to 10 hours used, using TEAC cleaner TZ-261A or moisten clean cloth with alcohol. Carefully wipe the face of each head and the tape guidance components to remove all traces of dirt and magnetic oxide deposits. TZ-261B for Rubber cleaning must be used on the pinch roller, capstan belt, counter belt etc.

-LUBRICATION-

Most of the rotating parts of the tape transport are permanently lubricated. There are, however, eight points which require periodic lubrication. They are the three motor, the capstan shaft and the pinch roller shaft using TEAC TZ-255 oil is recommended.

NOTE: If the motor pulley, capstan belt, flywheel and pinch roller become soiled with oil or grease, slippage will occur. Remove all traces of grease or oil with TZ-261A/B.



Fig. 5-1 TEAC Cleaner

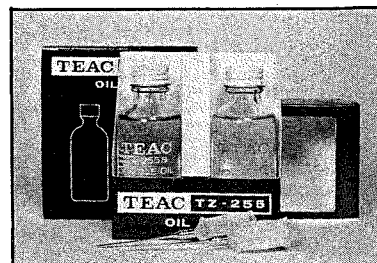

Fig. 5-2 TEAC Oil Kit

6. HEAD REPLACEMENT AND ALIGNMENT

6-1 HEAD REPLACEMENT

NOTE: Head alignment is adjusted at the factory to very critical tolerance.

Normally Head Ass'y replacement will require only minor alignments or adjustments. Complete re-adjustment will be necessary after a head is replaced. The adjustments are explained on the right.

— PROCEDURES —

To replace a single head, a special 2 mm nut driver is required. Remove the 2 nuts on the defective head through the access hole provided. This releases the head from the mounting plate. Note the position of the wires on the circuit board. Connect the new head in the same manner. Replace the nuts securing the new head to the plate. Perform head alignment before operation.

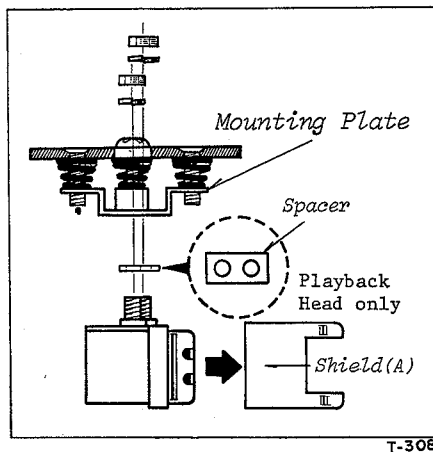

Fig. 6-1 Head Replacement

6-3 HEAD ADJ. SCREWS AND HEAD WIRING

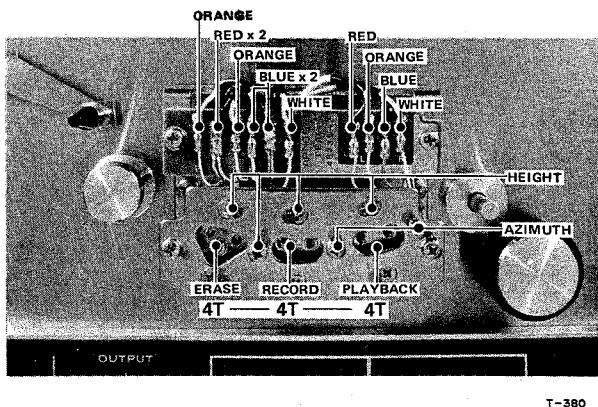

Fig. 6-3 Head adjustment screws and Head Wiring

6-2 HEAD ALIGNMENT

ERASE HEAD: The erase head pole should be above the edge of a threaded tape by the width of heavy pencil line. Turn the three screws indicated to obtain this height.

RECORD HEAD: The record head pole should be above the edge of a threaded tape by the width of a thin pencil line.

PLAYBACK HEAD: The pole of the playback head should be even with the top of a threaded tape. Turn the three screws indicated to obtain this height.

NOTE: After these adjustments have been made, be sure that all head surfaces are parallel with the tape guide surfaces when viewed from the side.

Azimuth adjustments are given in the section on MEASUREMENT AND ADJUSTMENT

— ELECTRICAL —



Fig. 6-2 Head Alignment

6-4 MIS-ALIGNMENT OF THE HEADS

ALIGNMENT— The physical positioning of a tape head relative to the tape itself. Alignment in all respects must conform to rigid requirements in order for a unit to function properly.

AZIMUTH— The angle of a tape head pole-piece slot relative to the direction of tape travel.

NOTE: In order for a tape unit to work at its best, with its own tapes as well as ones made on other units, its play and record heads must be aligned to correct 4 possible errors as illustrated below.

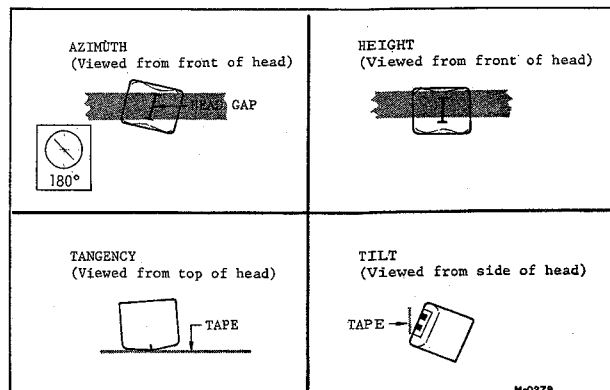

Fig. 6-4 Head Mis-Alignment — Examples —

7. MEASUREMENT AND ADJUSTMENT

-MECHANICAL-

The TEAC A-2300SD uses a highly reliable 3 motor drive system and should require a minimum of mechanical maintenance or adjustment. These adjustments are made at the factory. Readjustment should only be required after many hours of operation or component replacement.

7-1 PINCH ROLLER PRESSURE

NOTE: Pinch roller pressure is supplied by the pinch roller spring arm and it is most important that the solenoid plunger be fully bottomed before taking pressure measurement.

1. Load tape or block the shut-off arm in the ON position.
2. Attach a suitable spring scale to the pinch roller shaft.
3. Place the unit in the PLAY mode (▶), and holding the spring scale as illustrated, slowly draw it away from the pinch roller.
4. Do not allow the string to rub against the pinch roller.
5. Note the reading on the spring scale at the instant the pinch roller stops rotating.
6. The scale should indicate 2.0 to 2.2kg. Optimum value is 2.2kg (5.6 lbs).
7. If adjustment is necessary, loosen the 3 screws on the capstan solenoid and position the solenoid for optimum pressure.
8. Adjust solenoid-limit position so that the gap between capstan shaft and pinch roller is approx. 7mm when solenoid is not actuated. Limit is adjusted by loosening the mounting screw (A), then sliding limit until proper position is obtained.

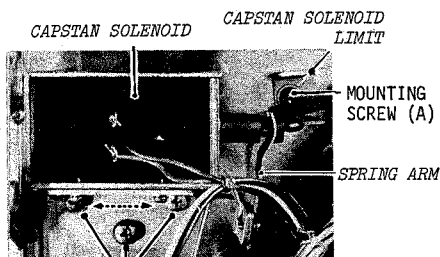

※ REPOSITION SOLENOID TO OBTAIN OPTIMUM PRESSURE

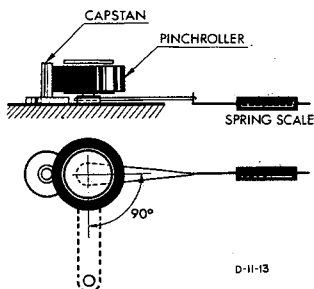

Fig. 7-1 Pressure Measurement and Adj. Locations

7-2 BRAKE TORQUE

The brake torque is actuated mechanically. Pressure is set by the variable spring force. While making these measurements and adjustments, be careful not to bend the brake bands. As brake torque will change with cleaning, brake drums and brake shoes should be cleaned only when absolutely necessary. If cleaning is required, use TEAC cleaner TZ-261B. After cleaning, operate the brakes by depressing the play and STOP buttons several times to completely dry out the brakes before performing the following procedure.

NOTE: Brake adjustments are made with NO power connected to the equipment.

1. Place an empty 4" hub reel on the left reel table, and fasten one end of a 30" length of string to the reel anchor.
2. Wind several turns of string counterclockwise around the hub and attach a suitable spring scale to the free end of the string.
3. Take a reading only when the reel is in steady motion since the force required to overcome static friction will produce a false, excessively high initial reading.
4. The reading should be 1000 g-cm \pm 200 g-cm. (14 oz-in).
5. If adjustment is required, loosen the 2 screws shown and position the brake for optimum torque.
6. The adjustment of the right brake is the same, with the exception that rotations are clockwise. (wind string CLOCKWISE around reel hub).

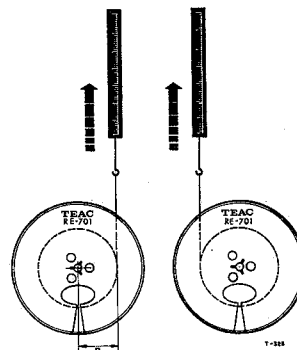
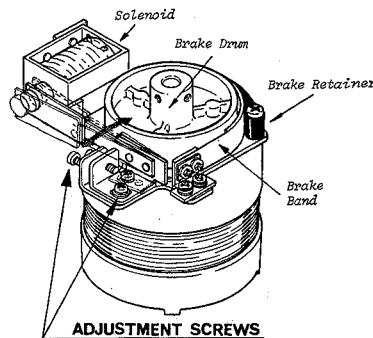

Fig. 7-2 Torque measurement and Adjustment Location

TORQUE MEASUREMENT PROCEDURE

All Torque and Tension Measurements must be made with the automatic shut-off switch (right tension arm) blocked to the ON position.

7-3 BACK TENSION

1. Place an empty 2" hub reel on the left reel table, and fasten one end of a 30" length of string to the reel anchor.
2. Wind several turns of string counter-clockwise around the hub. Attach spring scale to string.
3. Place the unit in the (▶) Play mode.
4. Pull the scale away from the reel against the motor torque with a steady smooth motion.
5. Note the scale reading while it is in steady motion. (The string must not rub the reel flanges)
6. Adjust R-2 as needed to obtain tension of 180 to 210g-cm (2.8 to 3.1 oz-in).

7-4 TAKE-UP TORQUE

1. Place the empty reel and attached spring scale on the right reel table.
2. Place the unit in the (▶) Play mode.
3. Allow the rotation of the reel to slowly draw the scale toward the hub.
4. Hold the spring scale with enough force to allow a steady reading.
5. It should be approx. 380 to 400 g-cm (4.1 to 4.8 oz-in).
NOTE: To measure torque when using a reel with a hub radius of other than (2") refer to following table;

FORMULA FOR TORQUE CALCULATION:

$$T \text{ (g-cm)} = r \times W$$

r: radius of hub (cm)
W: grams (read on spring scale)

Adjustment Location

If necessary, adjust slider of the resistors until you have the correct scale reading to optimum torque. Refer to adj. location below.

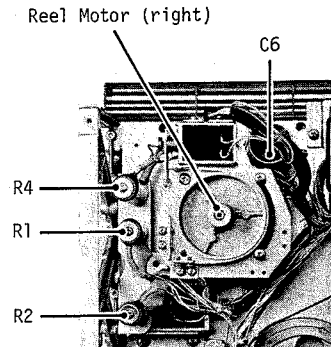

- R1 for TAKE-UP TORQUE
R2 for BACK TENSION
R4 for FAST FORWARD BACK TENSION (FIXED)

Fig. 7-3 Adjustment Location

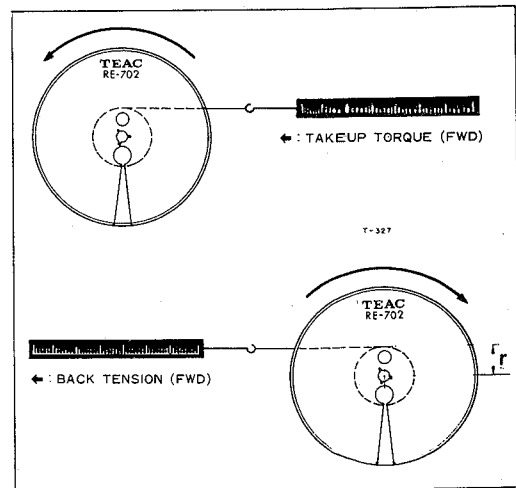

Fig. 7-4 Torque Measurement

7-5 REEL HEIGHT ADJUSTMENT

First check the tape movement by loading a tape using 7" Standard reels and running the tape in the play mode. If tape rubs against the side of reel, remove reel and adjust screw. Then recheck by loading reel again. Repeat adjustment until tape travels smoothly without rubbing sides of reel.

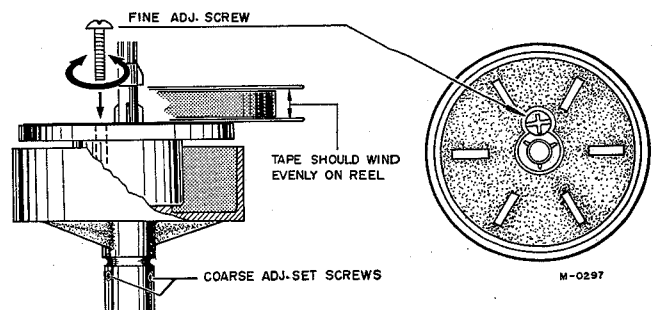

Fig. 7-5 Reel height adj.

7-6 TAPE SPEED

The tape speed should be measured using TEAC flutter free tape, Model YTT-2003 (7-1/2 ips), YTT-2002 (3-3/4 ips). These tapes contain a highly accurate 3 kHz tone. Connect a digital frequency counter to either line OUTPUT jack. The indicated frequency should be 3 kHz (± 30 Hz or less) for both speeds.

7-7 FLUTTER

Flutter should be measured in playback mode using a TEAC flutter free tape YTT-2003, 2002 and Meguro Denpa Co., MK668A flutter meter. Values obtained with different standard or equipment cannot be compared.

Flutter should not exceed value shown.

0.08% (WRMS), 0.18% (RMS) at 7-1/2 ips

0.10% (WRMS), 0.20% (RMS) at 3-3/4 ips

These figures apply to any tape position (such as full take-up reel, full supply reel or about mid point).

If there is excessive wow and flutter, examine the pinch roller, belt, motors, capstan shaft, and reel rest for "grease", "oil", "dirt" and/or "wear". Also examine the tape counter ass'y for evenness of operation.

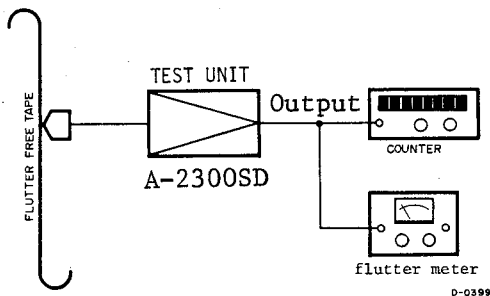

Fig. 7-6 Test Equipment Set-Up

7-8 VOLTAGE AND FREQUENCY CONVERSION

Unit must be set to the power line frequency available. Improper frequency setting will result in a 20% error for the Tape speed. (US model is preset to 117V AC and 60 Hz frequency and voltage conversion is not required).

If it should be necessary to convert the A-2300SD deck to operate from a power source of different voltage of frequency, it may be easily accomplished as follows:

– VOLTAGE CONVERSION –

The A-2300SD (EX) model may be set for 100, 117, 200, 220, or 240 volts. To change the voltage, unscrew the fuse in the center of the voltage selector plug. Pull out the plug and reinsert it so the desired voltage shows in the cut-out. Reinstall the fuse.

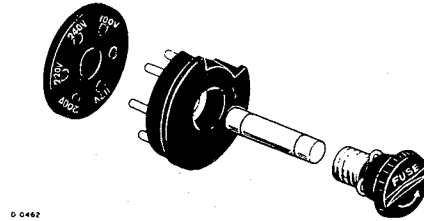

Fig. 7-7 Voltage Conversion

– FREQUENCY CONVERSION –

1. Remove the power cord and all connecting cables.
2. Take off tape deck rear cover by removing the 6 screws holding it.
3. To convert the unit from 50 Hz to 60 Hz operation reposition the capstan belt as shown in the illustration below.
4. Frequency selector slide switch inside the rear of the tape deck must be switched to the frequency of the power line.
5. Reinstall rear cover.

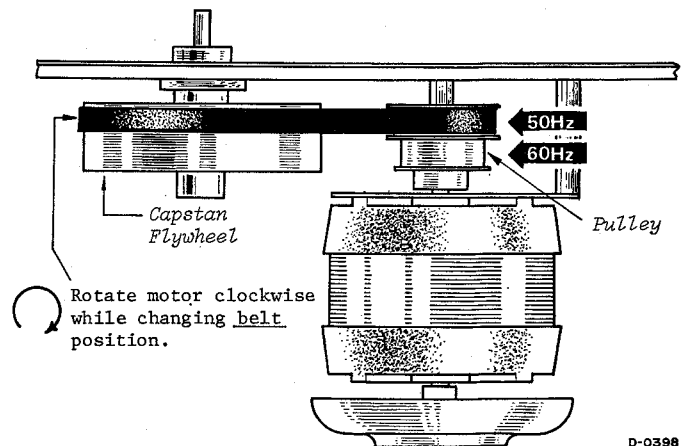

Fig. 7-8 Frequency Conversion

8. SIMPLIFIED DIAGRAM

8-1 BLOCK DIAGRAM

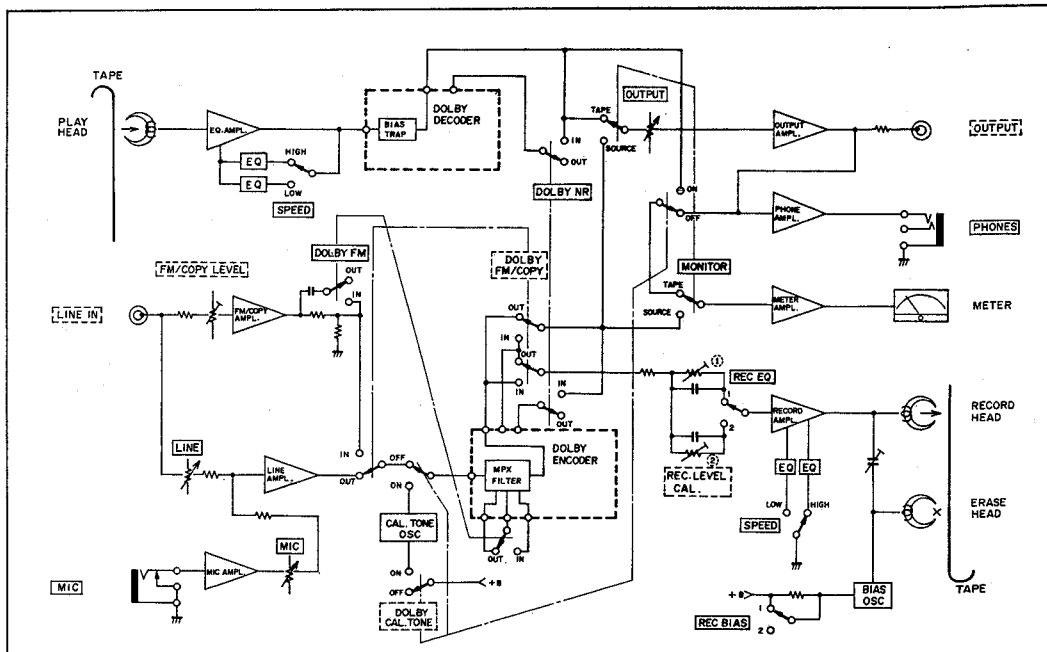

Fig. 8-1 Block Diagram

8-2 LEVEL DIAGRAMS

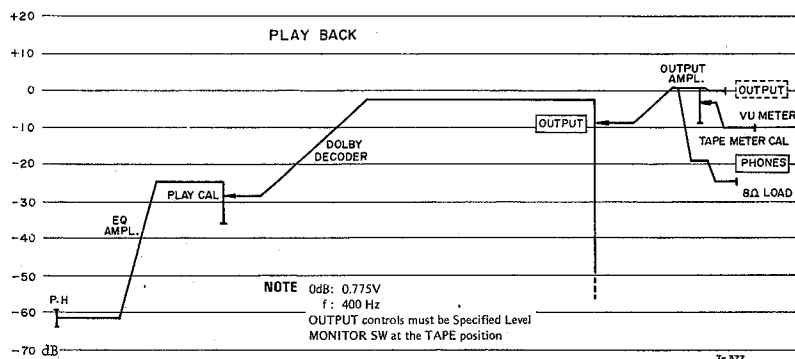

Fig. 8-2 Level Diagram – Playback

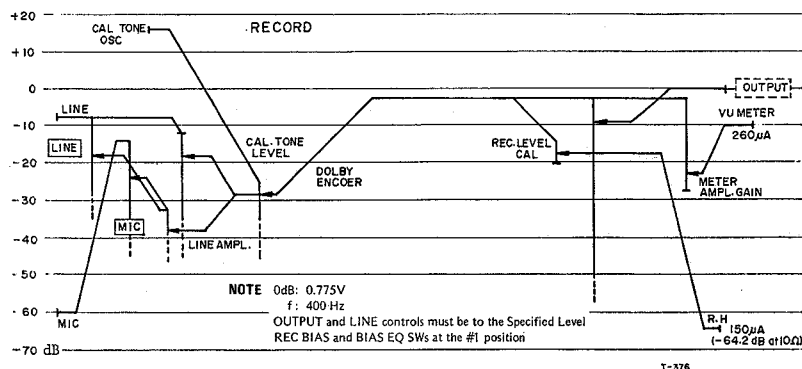
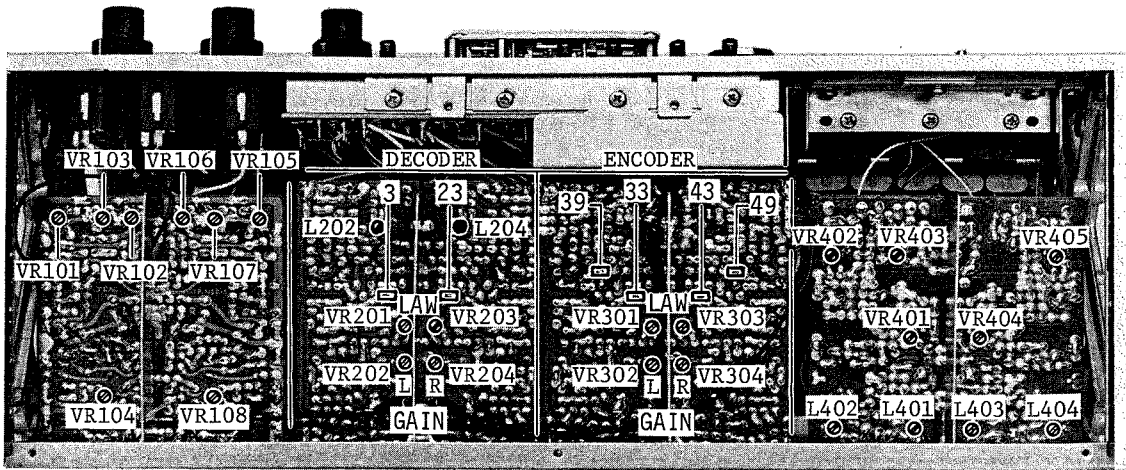

Fig. 8-3 Level Diagram – Record –

9. MEASUREMENT AND ADJUSTMENT

-ELECTRICAL-

9-1 ADJUSTMENT LOCATIONS



ADJUSTMENT IDENTIFICATION

L channel/R channel

VR101/VR105 — PB. GAIN adj.	VR201/VR203 — (LAW)	* VR402/VR405 — Meter Cal.
VR103/VR107 — PB. Eq. (Low)	VR202/VR204 — (GAIN)	VR403 — CAL TONE Level cal.
VR102/VR106 — PB. Eq. (High)	VR301/VR303 — (LAW)	* VR401/VR404 — Meter Cal.
VR104/VR108 — REC GAIN adj.	VR302/VR304 — (GAIN)	L402/L404 — Rec Eq. adj.
		L401/L403 — Bias Trap

The A-2300SD DOLBY DECODER and ENCODER adjustments themselves are critical and should only be performed by skilled technicians.

- * Adjust VR402/VR405 for CAL TONE SW at IN
- * Adjust VR401/VR404 for CAL TONE SW at OFF
- * Adjust L202/204 for minimum Bias leakage

Fig. 9-1 Adjustment Location — Bottom View —

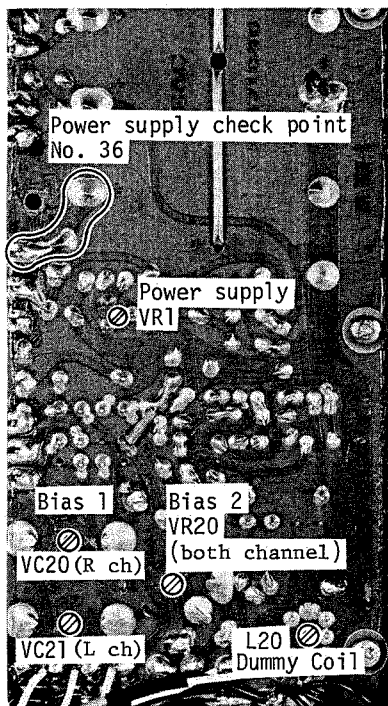
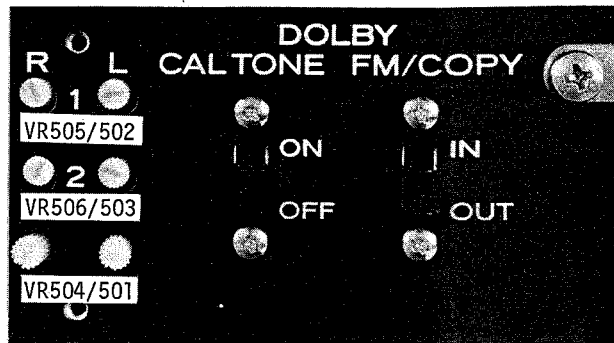

Fig. 9-2 BIAS OSC P.C.B. Adj. Location

Lower right side of chassis (see REAR VIEW on p5)



L ch/R ch

VR502/VR505 — Rec Level 1
VR503/VR506 — Rec Level 2
VR501/VR504 — Dolby NR

Fig. 9-3 Back panel Adj. Location

L ch/R ch

VC21/VC20 — Bias adj.
REC BIAS SW at 1
VR20 — Bias adj.
REC BIAS SW at 2
for both channels
L20 — Dummy coil
for mono Recording

9-2 ADJUSTMENT SEQUENCE CHART

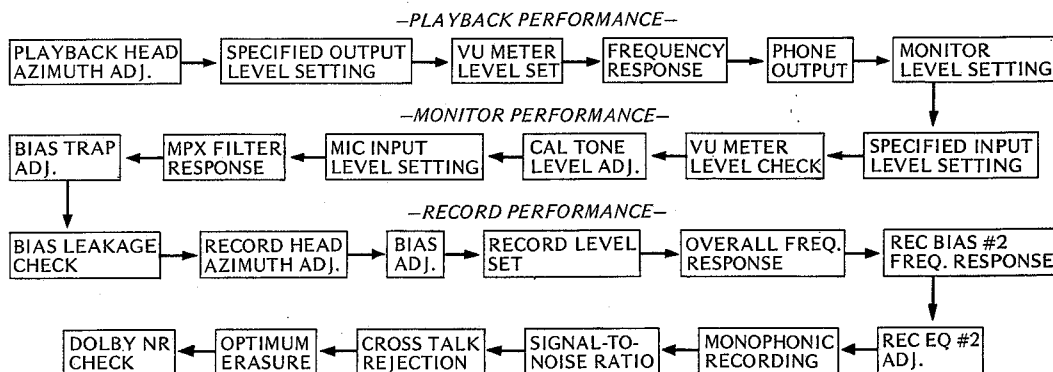

9-3 POWER SUPPLY CHECK AND ADJ.

1. Remove wooden panel on the right side by removing 4 mounting screws.
2. Place the power SW to the ON position.
3. Connect a VTVM to the junction of No. 36 AMP + B (on BIAS OSC PC Board) and ground.
4. Check the voltage at VR-1 and adjust for +23V DC.

9-4 PLAYBACK HEAD AZIMUTH ADJ.

— COARSE ADJUSTMENT —

1. Connect a VTVM to either OUTPUT jack.
2. Remove the head Housing (on front panel).
3. Thread the TEAC YTT-1003 Test Tape on the unit.
4. Place the Tape SPEED SW at 7-1/2 ips (HIGH). Play the 16 kHz Test Tone in section 2 of the Test Tape.
5. Slowly rotate the azimuth screw until maximum indication is achieved on VTVM.

— FINE ADJUSTMENT —

6. Connect the test equipment as shown in Fig. 9-4.
7. Play a 40 Hz to 10 kHz signal and adjust the Azimuth screw until the oscilloscope shows that the signals are less than 45° out of phase.
8. Secure this screw with a drop of Locking Paint.

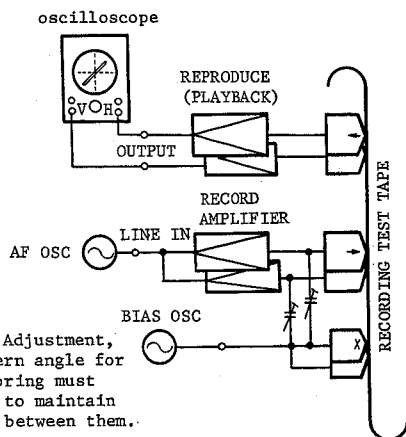

During Record Azimuth Adjustment, the oscilloscope pattern angle for SOURCE and TAPE monitoring must be identical in order to maintain a 0° phase difference between them.

Fig. 9-4 Head Alignment Fine Adjustment Set-Up

9-5 SPECIFIED OUTPUT LEVEL SETTING

1. Place the MONITOR SW to the TAPE position.
2. Turn the OUTPUT control fully clockwise.
3. Set DOLBY NR SW to OUT position.
4. Thread TEAC Test Tape YTT-1003 on the unit.
5. Operate at 7-1/2 ips (HIGH) speed.
6. Play the 400 Hz in Section 1 of the Test Tape.
7. Adjust Play Gain VR-101/105 for 580 mV at the Test Points (3,23) on the DOLBY DECODER PC Board, using a VTVM (1 meg ohm input Z or over) connected between each Test Point and ground.
8. Align the reference marks of the OUTPUT controls to the 0 VU (3 O'clock) position. This will give approx. 0 dB (775 mV) at the OUTPUT jacks.

NOTE: This is the Specified Output level setting. Do not disturb this setting until the remaining adjustments have been completed. During the following check and adjustment always keep 580 mV at the DOLBY ENCODER Test Points.

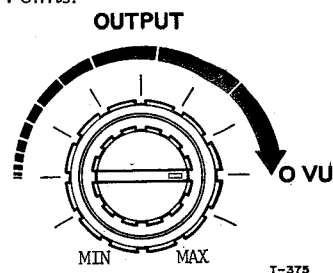

Fig. 9-5 Specified Output Level Setting

9-6 VU METER LEVEL SET

1. With controls set as described above:
 - a. Place the CAL TONE SW on the back panel to the IN position.
 - b. Adjust VR-402/405 for 0 VU reading on the VU Meter.
2. Change the CAL TONE SW to OFF position and adjust VR-401/404 for 0 VU reading on the VU Meter.

9-7 FREQUENCY RESPONSE-PLAYBACK-

1. Place Tape SPEED SW in 7-1/2 ips (HIGH) position.
2. Thread a TEAC Test Tape YTT-1003 on the unit.
3. Compare the readings obtained on the Test-Set (VTVM) with the Response Limits given in Fig. 9-6.
4. If adjustment is required, adjust VR-102/106 for HIGH speed.
5. Change Tape SPEED SW to 3-3/4 ips (LOW) position.
6. Thread a Test Tape YTT-1002 on the unit.
7. Repeat Step 3. Check for freq. response.
8. If adjustment is required, adjust play EQ VR-103/107 for LOW speed.

NOTE: If the frequency response does not meet specified response limits, especially at the high-end of the spectrum, head should be checked for accumulated dirt or oxides. If clean, head azimuth must be readjusted.

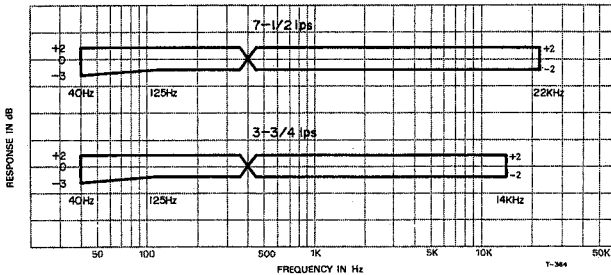

Fig. 9-6 Frequency Response - Playback -

9-8 PHONE OUTPUT CHECK

1. Place OUTPUT control at the SPECIFIED level setting (400 Hz/0 dB).
2. Connect an 8Ω non-inductive resistor across the headphone jacks. Connect VTVM or Equivalent across the resistor.
3. VTVM should indicate -24 dB ±2 dB. (4.9 mV).

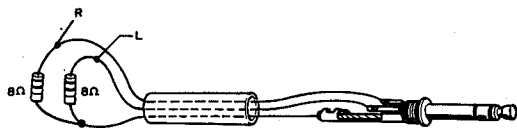

Fig. 9-7 Headphone Connecting Resistors

9-9 MONITOR LEVEL SETTING

1. Connect an AF oscillator to the LINE IN jacks.
2. Place MONITOR SW in SOURCE position.
3. Apply a 400 Hz signal -18 dB (97 mV) to the LINE IN jacks.
4. Turn LINE control fully clockwise.
5. Adjust VR-104/108 for 580 mV (-2.5 dB) at the DOLBY ENCODER Test Points (39, 49).
6. Check for 0 dB (775 mV) at the OUTPUT jacks.

9-10 SPECIFIED INPUT LEVEL SETTING

1. Apply a 400 Hz signal at -8 dB (308 mV) to the LINE IN jacks.
2. Adjust both LINE Controls simultaneously for 0 dB at OUTPUT jacks. If both channels do not read 0 dB at the same position of the LINE Controls, set the LINE Controls so that the higher reading channel reads 0 dB. Then adjust VR-104 or VR-108 so that the lower channel reads 0 dB.

NOTE: At this point both the LINE Controls and the OUTPUT Controls are at the "Specified setting". Do not move these controls unless instructed in this procedure to do so. The accuracy of many of the following adjustments and readings depends on these controls being at the "Specified setting".

9-11 VU METER LEVEL CHECK

3. With controls set as described above, check for 0 VU indication on the VU Meters.

9-12 CAL TONE LEVEL ADJUSTMENT

With controls set as described above in MONITOR LEVEL SETTING:

1. Place the CAL TONE SW on the back panel to the IN position.
2. Adjust VR-403 for 0 VU on the VU Meter.
3. If readings between channels are different, balance the readings around 0 VU.

NOTE: The following checks and adjustments must be performed with the CAL TONE SW in the OFF position.

9-13 MIC INPUT LEVEL CHECK

This is check only, No adjustment are to be made.

1. Set MIC controls fully clockwise.
2. Apply a 400 Hz signal at -70 dB to the MIC input jacks.
3. Check for 0 dB level at OUTPUT jacks.
4. With 0 dB at OUTPUT jacks, MIC input level should be -70 dB ±2 dB.
5. Return MIC controls fully counter clockwise to prevent noise insertion during following steps.

9-14 MPX FILTER RESPONSE CHECK

1. Apply a 19 kHz, -8 dB signal to the LINE IN jacks.
2. Place the DOLBY FM SW to IN position.
The level indication on the VTVM should decline by 30 dB or more with the DOLBY FM SW IN compared to the level with the DOLBY FM SW to OUT.

9-15 BIAS TRAP ADJUSTMENT

1. Remove all input signals.
2. Set MONITOR switches to SOURCE and REC MODE switches to ON.
3. Set REC BIAS switch to #1 position.
4. Load TEAC YTT-8013 test tape on the unit.
5. Connect a VTVM or oscilloscope from ground to the junction of L-401 and C-403 (L ch) and from ground to the junction of L-403 and C-425 (R ch).
6. Adjust L-401 (L ch) and L-403 (R ch) for minimum reading on scope or VTVM. Use non-inductive screw driver.

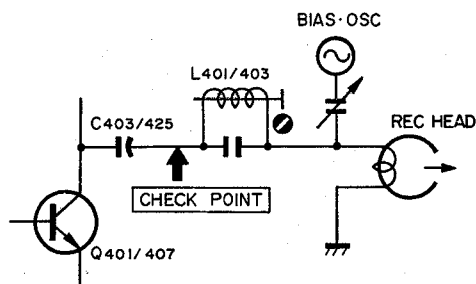

T-372

Fig. 9-8 Bias Trap Check Point

9-16 BIAS LEAKAGE CHECK

7. Change the MONITOR SW to TAPE position.
8. Adjust L-202/204 (on DOLBY DECODER PC Board) for minimum bias leakage reading at OUTPUT jacks. Spec. -40 dB or less.

9-17 RECORD HEAD AZIMUTH ADJUSTMENT

The following adjustments are made only at 3-3/4 ips (LOW) speed.

COURSE ADJUSTMENT

NOTE: The effect of turning the azimuth screw will not immediately register on the VTVM. A slight delay will be noticed. Therefore, the screw must be rotated slightly with a pause to see the effect.

1. Thread a record test tape YTT-8013 or equivalent tape on the unit.
2. Connect a VTVM to the OUTPUT jack and an AF oscillator to the LINE IN jack. Set the oscillator to 5 kHz at -18 dB.
3. Place the MONITOR switches to TAPE position.
4. Begin recording (Depress REC and ► play buttons).
5. While recording adjust the azimuth screw for maximum reading on the OUTPUT VTVM.

FINE ADJUSTMENT

NOTE: It is absolutely essential to accomplish the course adjustment before performing the fine adj. to avoid phase errors greater than 45°.

6. Connect the test equipment as shown in figure 9-4.
7. Apply a 7.5 kHz signal at -18 dB to the LINE IN jacks and record this signal.
8. Carefully adjust the azimuth screw until the oscilloscope shows the signal to be in phase.
9. Secure the screw with insulating locking paint.

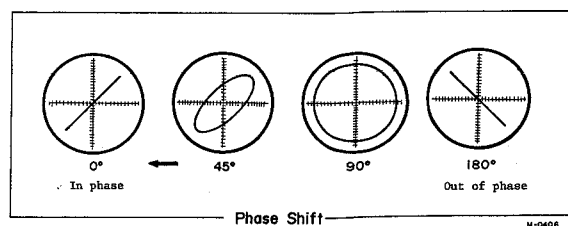

Fig. 9-9 Phase Shift

9-18 BIAS ADJUSTMENT

1. Place REC BIAS switch to #1 and REC EQ switch to #1.
2. Place MONITOR switch in the TAPE position.
3. Apply 7 kHz signal at -18 dB to the LINE IN jacks.
4. Adjust capacitor VC-20/21 for a peak reading on the VTVM, then turn the capacitors clockwise until a decrease of 2.5 dB from the peak is obtained.

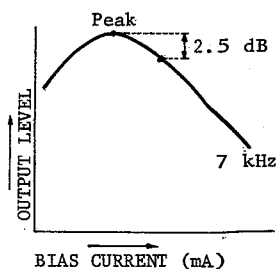

Fig. 9-10 Bias Limits Chart

9-19 REC EQ #1 LEVEL SET

1. Thread a record Test Tape TEAC YTT-8003 on the unit.
2. Apply a 400 Hz signal at -8 dB to the LINE IN jacks.
3. Place Tape SPEED SW to the 7-1/2 ips (HIGH) position.
4. Begin recording.
5. Adjust REC LEVEL CAL VR-502/505 (on the back panel) for 0 dB at OUTPUT jacks.

9-20 OVERALL FREQUENCY RESPONSE

1. Place the DOLBY NR SW to OUT position.
2. Place REC EQ SW and REC BIAS SW at #1 position.
3. Place Tape SPEED at 7-1/2 ips (HIGH) position.
4. Adjust the AF oscillator to obtain an Output level of -28 dB at OUTPUT jacks.
5. Apply signals swept from 40 Hz to 24 kHz to the deck while recording on a record Test Tape (TEAC YTT-8013). Refer to response limits below.
6. Repeat the above procedure for 3-3/4 ips (LOW) using signals from 40 Hz to 16 kHz.
7. If the response is not uniform, the heads should be checked for accumulated oxide and dirt.
8. If heads are clean, the equalization coil L-402 (L-CH) and L-404 (R-CH) should be adjusted.
9. Adjustment of coils should be done while in HIGH position for both speeds.

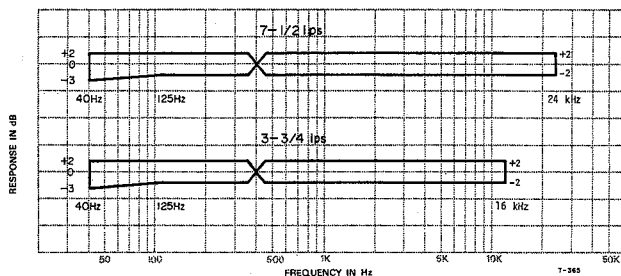

Fig. 9-11 Frequency Response Limits - Record -

10. Place DOLBY NR SW to IN position.

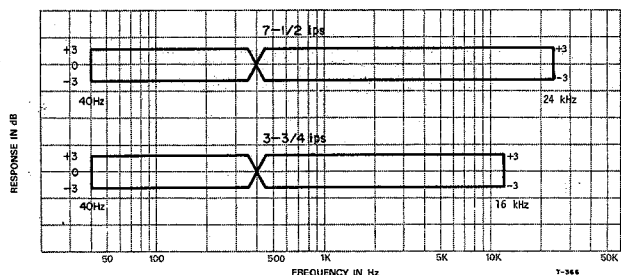

Fig. 9-12 Frequency Response Limits - Record -

9-21 REC BIAS #2 FREQUENCY RESPONSE CHECK

1. Place the REC EQ SW to #1 position, BIAS SW to #2 position.
2. Place Tape SPEED SW to 7-1/2 ips (HIGH) position.
3. Thread a record Test Tape YTT-8003 on the unit.
4. Adjust VR-20 for best frequency response. (adjusts both channels together)
5. Repeat Overall response check at LOW speed. Both speeds refer to response Limits given in figure 9-11 and 9-12.

9-22 REC EQ #2 LEVEL SET

1. Thread a record Test Tape YTT-8003 on the unit.
2. Apply a 400 Hz signal at -8 dB to the LINE IN jacks.
3. Place REC EQ SW to the #2 position.
4. Place Tape SPEED SW to 7-1/2 ips (HIGH) position.
5. Adjust REC LEVEL CAL VR-503/506 (on the back panel) for +0.8 dB at OUTPUT jacks.

9-23 MONOPHONIC RECORDING

1. Place the RECORD MODE SW L (or R, not both) to ON and R (or L) to the OFF position.
2. Apply signals swept from 40 Hz to 24 kHz at -28 dB to LINE IN jacks and record. Use record Test Tape YTT-8003 or equiv.
3. If necessary, adjust L-20 (on the BIAS OSC PC Board) for best response.

9-24 SIGNAL-TO-NOISE RATIO (PLAYBACK)

1. OUTPUT controls should be at the Specified Output Level settings.
2. Thread a blank YTT-8003 on the unit leaving the tape outside the capstan and pinch Roller.
3. Hold the play supply reel stationary and depress the play (▶) button.
4. The DOLBY NR SW must be at OUT position.
5. The Test-Set (VTVM) connected to the OUTPUT jacks should indicate listed below.
7-1/2 ips 52 dB (unweighted), 60 dB (weighted)
3-3/4 ips 50 dB (unweighted), 60 dB (weighted)

9-25 SIGNAL-TO-NOISE RATIO (OVERALL)

1. OUTPUT and LINE controls should be at the Specified position.
2. Thread a blank Test Tape YTT-8003 on the unit.
3. Remove the AF oscillator from the LINE IN jacks.
4. Place the unit in the REC mode with "no signal" applied. Note the point on the index counter where recording begins.
5. Rewind the tape to the beginning point and play it back.
6. The noise level as indicated on the Test-Set should be readings listed below.
* DOLBY NR OUT position
7-1/2 ips 50 dB (unweighted), 53 dB (weighted)
3-3/4 ips 48 dB (unweighted), 50 dB (weighted)
* DOLBY NR IN position
7-1/2 ips 52 dB (unweighted), 62 dB (weighted)
3-3/4 ips 50 dB (unweighted), 62 dB (weighted)

9-26 TRACK-TO-TRACK CROSS TALK REJECTION

Following is the measurement procedure at 7-1/2 ips using the TEAC standard tape, Type YTT-8013:

1. Thread a blank tape or the YTT-8013 tape on the unit.
2. Apply a 125 Hz signal at -8 dB to the right channel LINE IN jack.
3. Make a 30 second recording of the 125 Hz signal.
4. Interchange the left and right reels and rethread tape on the unit.
5. Connect a VTVM to the right channel OUTPUT jack.
6. Playback the recorded signal portion of tape and monitor the level on the VTVM.
7. The reading should be -35 dB or less.

9-27 CHANNEL-TO-CHANNEL CROSS TALK REJECTION

Following is the measurement procedure at 7-1/2 ips using the TEAC standard tape, Type YTT-8013:

1. Apply a 1 kHz signal at the operating level of -8 dB, to the left channel LINE IN jack.
2. Install a short-circuiting plug to the right channel LINE IN jack.
3. Make a 30 second recording on both channels, then rewind to beginning of this recording.
4. Connect a VTVM or equivalent, to the right channel OUTPUT jack through a 1 kHz Narrow Band Pass Filter.
5. Put unit in PLAY mode and monitor the "no signal" right channel on the VTVM.
The reading should be -45 dB or less.

9-28 OPTIMUM ERASURE MEASUREMENT

1. Apply a 1 kHz signal at 10 dB above the operating level of -8 dB, to the left channel LINE IN jack.
2. Make a 30 second recording of the above signal and rewind to beginning of this recording.
3. Disconnect the 1 kHz signal source (A.F oscillator) from the LINE IN jack.
4. Connect a VTVM or equivalent, to the left channel OUTPUT jack, through a 1 kHz Narrow Band Pass Filter
5. Set the unit output switch to "TAPE monitor".
6. Put unit in the REC mode and "record" (erase) over this previous recording; then rewind to beginning again.
7. Put unit in PLAY mode and monitor the left channel output on the VTVM.
8. Difference in output level, compared to the above recording level, should be more than -68 dB.
9. Repeat the same procedure on the right channel.

9-29 DOLBY ENCODER CHECK (PLAYBACK)

1. Place the DOLBY NR SW to IN, FM/COPY SW to IN, and the MONITOR SW to SOURCE position.
2. Turn the FM/COPY LEVEL L and R (VR-501/504) on the back panel to maximum.
3. Apply a 100 Hz signal at -38 dB at the LINE IN jacks.
4. Adjust FM/COPY LEVEL L and R for -30 dB at OUTPUT jacks.
5. Change the Input signal frequency to 5 kHz at -48 dB. The OUTPUT level should read -50 dB \pm 1 dB.
6. If readings are not within limits, recheck adjustments of DOLBY ENCODER PC Board.

9-30 DOLBY DECODER CHECK

6. Place the DOLBY FM/COPY SW to OUT, DOLBY NR SW to OUT, REC BIAS SW and REC EQ SW to #1 position, tape SPEED SW to 7-1/2 ips (HIGH) position.
7. Thread a blank TEAC YTT-8013 on the unit.
8. Record approx. 10 seconds each of a 1 kHz signal at -28 dB and a 10 kHz signal at -48 dB.
9. Rewind the tape, playback the recorded signals but while watching the VTVM set the DOLBY NR SW to IN position.
10. Comparing the outputs between DOLBY NR SW-OUT/IN, check at 1 kHz for a decline of 5 dB; at 10 kHz for decline of 10 dB.
11. If readings are not within limits, recheck and adjust DOLBY DECODER PC Board.

9-31 DOLBY NR CHECK

12. Place the DOLBY FM/COPY SW to OUT, DOLBY NR SW to IN position. REC BIAS SW and REC EQ SW to #1 position, tape SPEED SW to 7-1/2 ips (HIGH).
13. Apply signals swept from 40 Hz to 22 kHz at -38 dB to LINE IN jacks and record.
14. Change the tape SPEED SW to the 3-3/4 ips (LOW) position.
15. Apply signals swept from 40 Hz to 16 kHz at -38 dB.
16. Check for best response. No further adjustment is provided.

10. TROUBLE SHOOTING

NOTE: The following guide lists specific difficulties that could occur in the A-2300SD.

Possible causes are listed for each malfunction. Visually inspect the unit for any damage such as broken or burned components or wiring, loose connections, etc.

MALFUNCTION	POSSIBLE SOURCE OF TROUBLE	CORRECTIVE PROCEDURE
Capstan fails to turn	Belt off or slipping, line fuse, safety switch (SW-2), speed select switch (SW-12), phase advance capacitor (C-5),rewind play relay (K-3)	Repair or replace the defective components.
Pinch roller fails to contact capstan in play mode	Operation relay (K-1) rewind relay (K-3), STOP micro-switch (S-4), PLAY (▶), micro-switch (S-7), capstan solenoid	Refer to schematic diagram and repair or replace the defective components.
Right reel motor does not rotate in play mode.	Reel motor (right), brake solenoid, rewind relay (K-3), resistor (R-1)	Replace the defective components.
Left reel motor does not rotate in play mode. Both motors fail to operate.	Reel motor (left), brake solenoid, rewind relay (K-3), resistor (R-2) Operating relay (K-1)	
Recorder does not operate in PLAY (▶)	Remote control jumper plug missing or loose, STOP micro switch (S-4), brake solenoid, rewind relay (K-3), phase advance capacitor (C-5)	Normal DC resistance of the brake solenoid is 1.3k ohms. Refer to schematic diagram and repair or replace the defective components.
Playback noise or hum	Faulty connections, faulty playback head, faulty amplifier	Repair or replace defective components.
Noise or hum during record	Magnetized head, faulty connections, MIC level set to maximum, faulty record amplifier, record relay (K-401)	Demagnetize and clean head, repair or replace defective components, check MIC VR.
Wow and flutter	Defective tape, dirty or defective pinch roller and pressure, oily or defective belt, reel motor torque.	Clean or replace defective components. Adjust motor torque.
Incorrect tape speed	Drive belt in wrong position. Incorrect pinch roller pressure.	Reposition drive belt. Adjust pinch roller pressure.
Brakes do not release	Defective brake solenoid.	The D.C. resistance of the brake solenoid should be 1.3k ohms. Replace solenoid.
Fast forward or rewind mode inoperative	Rewind relay (K-3)	Refer to schematic diagram and repair or replace the defective components.
No record and/or no erase	Record head dirty, erase head dirty, operate relay (K-1), record relay (K-401), REC micro switch (S-8), record amplifier, Bias OSC, record head, erase head.	Refer to schematic diagram and repair or replace the defective components.
No playback	Playback head defective or dirty, amplifier-to-deck connections, monitor switch (SW-501), playback amplifiers.	Refer to playback amplifier voltage chart.

PARTS LIST

CONTENTS OF PARTS LIST

Parts Ordering Information.....	22
Assembling Hardware Coding List	23
Included Accessories	31

11. Exploded Views and Parts List

11-1. Main Chassis Group	24
11-2. Motor Chassis Group	26
11-3. Front Panel	28
11-4. Rear Panel	30

12. PC Board Section

12-1. Amplifier A-circuit	32, 38
12-2. Control Relay	32, 38
12-3. Amplifier B-circuit	33, 38
12-4. Rear Panel PC Board	33, 39
12-5. Dolby "B" Processor	34, 40
12-6. Bias Oscillator	35, 42
12-7. Muting PC Board	36, 42
12-8. Control PC Board	36, 43
12-9. SW Mounting PC Board	37, 43

PARTS ORDERING INFORMATION

Spare parts are available through your nearest TEAC Authorized Service Center or directly from the TEAC office, the address of which is written on the back cover. When ordering parts, always include the following information:

- | | |
|--------------|--------------------|
| 1. MODEL | 4. DESCRIPTION |
| 2. REF. NO. | 5. UNIT SERIAL NO. |
| 3. PARTS NO. | 6. MANUAL CODE NO. |

NOTICE REGARDING PARTS ORDERS

- Do not order by only REF. NO.
- In some instances, individual minor parts are not available. In such a case, the entire assembly including the part requested will be sent to you.

PARTS IDENTIFICATION CODING

Parts are identical between the different models with the exceptions as coded by the designations explained below.

TCA	TEAC Corporation of America, U.S.A. version only
CAN (or CANADA)	Canada version only
EX	All export versions (except TCA, CAN or Japan).

ASSEMBLING HARDWARE CODING LIST

All screws conform to ISO standards, and have cross-recessed heads, unless otherwise noted.

ISO screws have the head inscribed with a point as in the figure to the right.

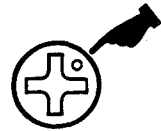

FOR EXAMPLE:

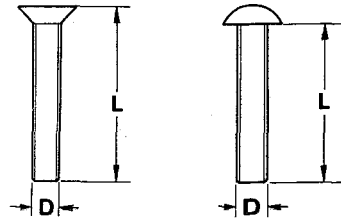
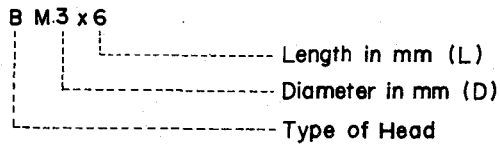

	Code	Full Name	Type		Code	Full Name	Type
MACHINE SCREW	R	Round Head Screw		TAPPING SCREW	BTA	Binding Head Tapping Screw(A Type)	
	P	Pan Head Screw			BTB	Binding Head Tapping Screw(B Type)	
	T	Stove Head Screw (Truss)			RTA	Round Head Tapping Screw(A Type)	
	B	Binding Head Screw			RTB	Round Head Tapping Screw(B Type)	
	F	Flat Countersunk Head Screw		SETScrew	SF	Hex Socket Setscrew(Flat Point)	
	O	Oval Countersunk Head Screw			SC	Hex Socket Setscrew(Cup Point)	
WOOD SCREW	RW	Round Head Wood Screw		SS	Slotted Socket Setscrew(Flat Point)		
	FW	Flat Countersunk Wood Screw		WASHER	E	E-Ring (Retaining Washer)	
	OW	Oval Countersunk Wood Screw			W	Flat Washer (Plain)	
SEMS SCREW	BSA	Binding Head SEMS Screw(A Type)			SW	Lock Washer (Spring)	
	BSB	Binding Head SEMS Screw(B Type)			LWI	Lock Washer (Internal Teeth)	
	BSF	Binding Head SEMS Screw(F Type)			LWE	Lock Washer (External Teeth)	
	PSA	Pan Head SEMS Screw(A Type)		TW	Trim Washer (Countersunk)		
	PSB	Pan Head SEMS Screw(B Type)		NUT	N	Hex Nut	

T-310

11. EXPLODED VIEWS AND PARTS LIST

11-1. MAIN CHASSIS GROUP

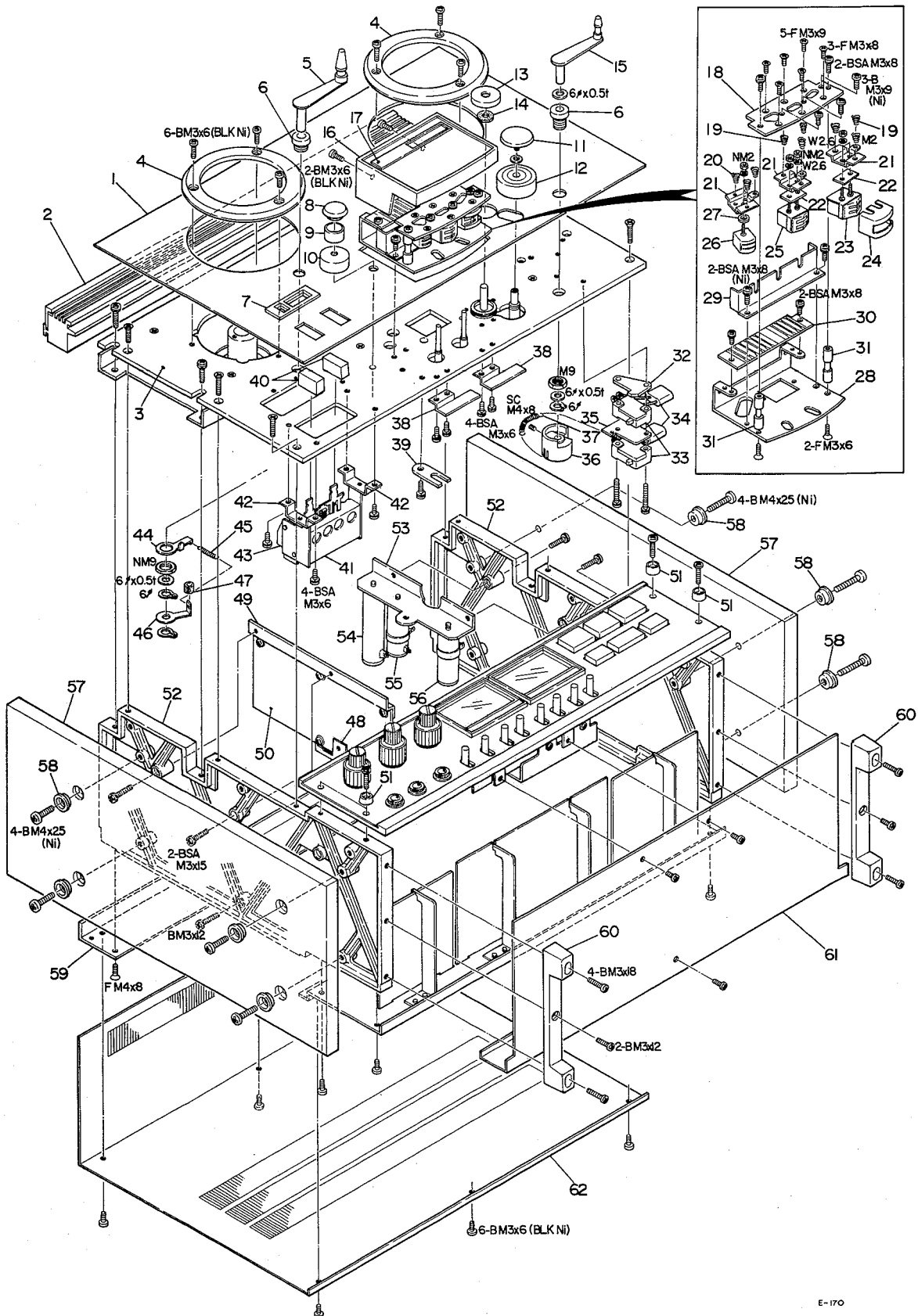

E-170

REF. NO.	PARTS NO.	DESCRIPTION	REMARKS
1- 1	50114250	Panel, Trim	
1- 2	50112980	Grille Assy, Top	
1- 3	50114275	Panel, Chassis	
1- 4	50161940	Reel Protector	
1- 5	50180590	Tension Arm Assy, Left	
1- 6	50182701	Bushing, Arm; A	
1- 7	50162980	Cover, Index Counter	
1- 8	50123910	Cap, Guide Ring	
1- 9	50123930	Ring, Guide	
1-10	50123921	Guide Ring Base	
1-11	55341290	Cap, Pinch Roller	
1-12	50141751	Pinch Roller	
1-13	50123971	Cap, Dust; 6φ	
1-14	50123900	Seal, Oil	
1-15	50180432	Tension Arm Assy, Right	
1-16	50136550	Head Housing	
1-17	55542620	Name Plate	
1-18	50134400	Plate, Head Base	
1-19	55201820	Spring, Head; D	
1-20	50220500	Spring, Head; B	
1-21	50134371	Plate, Head	
1-22	55501511	Spacer, Head; A	
1-23	50664550	Head, PB (4T-2CH)	
1-24	50133891	Head Shield, A	
1-25	50664560	Head, Record (4T-2CH)	
1-26	50663090	Head, Erase (4T-2CH)	
1-27	50136540	Spacer, Erase Head	
1-28	50136561	Plate, Housing Base; C	
1-29	50136690	Bracket, Head Protector	
1-30	50491121	PC Board, Head	
1-31	50182672	Pin, Guide	
1-32	50182730	Limit Stop, Right	
1-33	51300010	Switch, Micro; V-1A-44	
1-34	50529050	Spark Killer, 0.1μF+120Ω 400V	
1-35	50183931	Plate, Insul.	
1-36	50183921	Drum, Tension Arm	
1-37	50221122	Spring, Tension Arm; C	
1-38	55542870	Plate, VU Meter Support	
1-39	50331440	Plate, Chassis Panel	
1-40	50253890	Knob, Switch	
1-41	50443902	Switch Assy, POWER/SPEED	
1-42	50237470	Bracket, Switch Mounting	
1-43	50332671	Plate, Insul.; Micro Switch	
1-44	50276870	Anchor, Spring; Left	
1-45	50221110	Spring, B	
1-46	50182750	Travel Limiter, Tension Arm	
1-47	50276990	Collar, Rubber	
1-48	55542690	Angle, Reinforcing	
1-49	55530410	Angle, PC Board	
1-50	51681841	PC Bd. Assy, Bias Oscillator	
1-51	50277111	Washer, Trim	
1-52	50112713	Frame, Side	
1-53	50330110	Plate, Resistor Mounting	
1-54	50522380	Resistor, Wire Wound; 1,2kΩ 30H	
1-55	50524201	Resistor, Wire Wound; 100Ω 20HA	
1-56	50522370	Resistor, Wire Wound; 700Ω 20HA	
1-57	50288331	Sideboard	
1-58	50276930	Washer, Trim	
1-59	50235312	Angle, Rear Cover	
1-60	50277980	Leg, Case	
1-61	55040751	Cover Assy, Bottom	
1-62	55530310	Cover Assy, Rear	

11-2. MOTOR CHASSIS GROUP

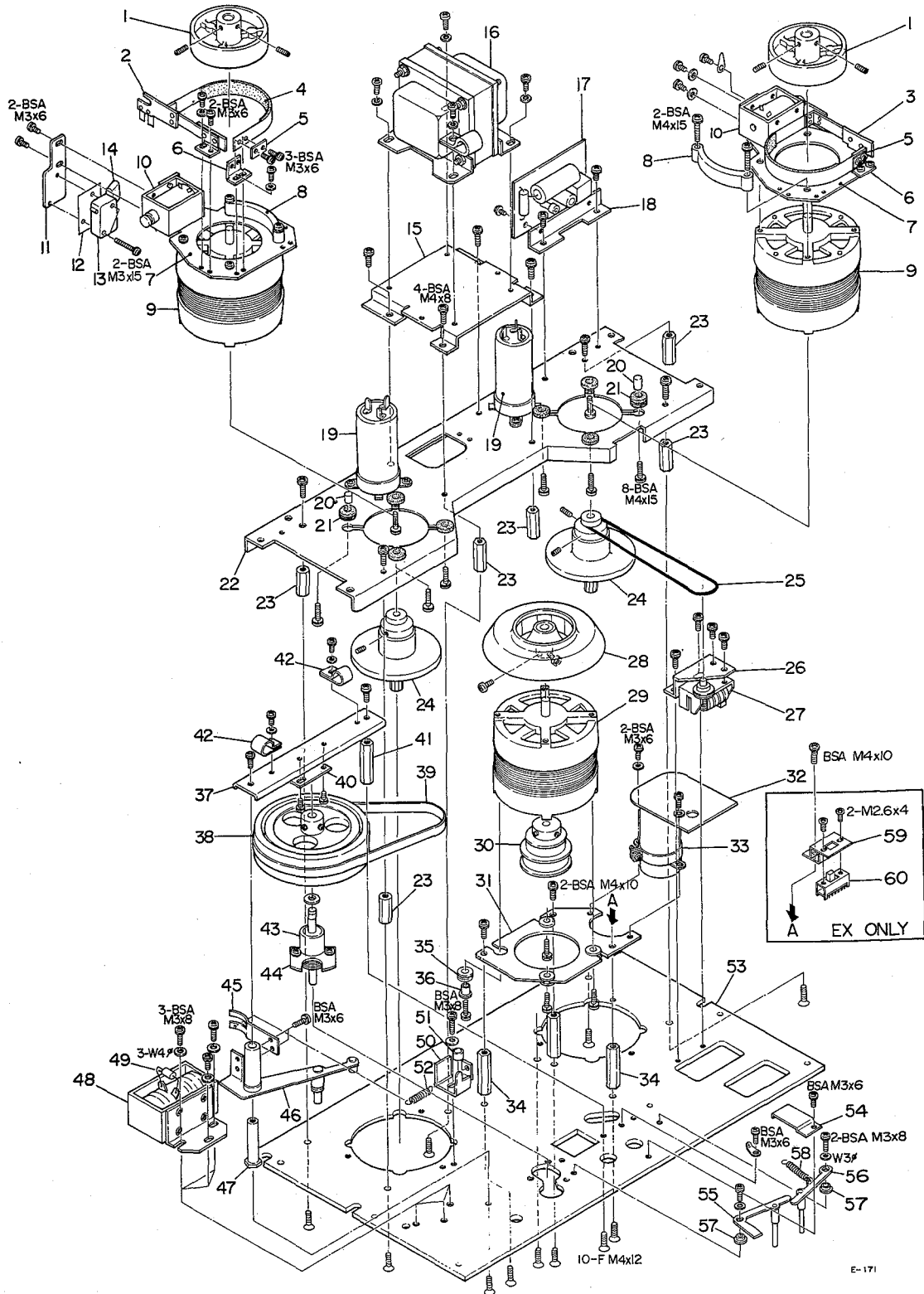

E-171

REF.NO.	PARTS NO.	DESCRIPTION	REMARKS
2- 1	50173560	Drum, Brake	
2- 2	50173661	Brake Band Assy, C	
2- 3	50170182	Brake Band Assy, A	
2- 4	50171382	Felt, Brake	
2- 5	50170150	Plate, Band Pressure	
2- 6	50170160	Angle, Band Mounting	
2- 7	50173650	Plate, Brake Band Assy	
2- 8	50172550	Brake Retainer	
2- 9	71041040	Motor, Reel	
2-10	50616770	Solenoid, Brake	
2-11	50173690	Bracket, Micro SW	
2-12	50332680	Insulator Plate, Micro SW	
2-13	50446180	Micro SW, V-1A-44	
2-14	50549920	Capacitor, Metalized Mylar; 0.1 μ F 400V	
2-15	50236650	Plate, Power Transformer	
2-16	51520370	Transformer, Power	
2-17	50491582	PC Bd. Assy, Control Relay	TCA/CANADA
	50491680	PC Bd. Assy, Control Relay	EX
2-18	50332573	Angle, PC Board	
2-19	50545940	Capacitor, MP; (3.9+0.9) μ F	
2-20	50162760	Spacer, Rubber Cushion	
2-21	50162960	Cushion, Rubber; B	
2-22	50237460	Chassis, Reel Motor; S	
2-23	50161950	Standoff, Reel Motor	
2-24	50160333	Reel Table Assy	
2-25	50332560	Belt, Counter	
2-26	50332520	Plate, Counter	
2-27	50585140	Counter, Index	
2-28	50123984	Fan, Motor Cooling	
2-29	50701341	Motor, Capstan	
2-30	50125121	Pulley, Motor (60Hz)	TCA CANADA
	50124003	Pulley, Motor (50Hz/60Hz)	EX
2-31	50237520	Plate, Capstan Motor Mounting	
2-32	50491401	PC Board Assy, Terminal (w/o Cap.)	
2-33	50545650	Capacitor, MP; (2+0.8) μ F 250V	
2-34	50123850	Standoff, Capstan Motor	
2-35	50706211	Cushion, Rubber	
2-36	50332790	Spacer, Rubber Cushion	
2-37	50277151	Angle, Thrust	
2-38	50123802	Flywheel, Capstan	
2-39	50123830	Belt, Capstan	
2-40	50277232	Plate, Thrust	
2-41	50123860	Standoff, Thrust	
2-42	50276280	Clamp, Wire	
2-43	50120440	Capstan Assy	
2-44	50142190	Plate, Arm Support	
2-45	50221152	Spring, Pressure	
2-46	50140236	Arm Assy, Pinch Roller	
2-47	50141821	Pivot, Roller Arm	
2-48	50616760	Solenoid Assy, Pinch Roller	
2-49	50422570	Diode, S1B01-06	
2-50	50141842	Limit Stop, Pinch Roller	
2-51	50275690	Cushion, Rubber	
2-52	50220441	Spring	
2-53	50114276	Panel, Chassis	
2-54	50152453	Plate, Lifter	
2-55	50150243	Arm, Lifter; A	
2-56	50150253	Arm, Lifter; B	
2-57	50152502	Pivot, Lifter Arm	
2-58	50221100	Spring, A	
2-59	50332380	Bracket, Slide Switch	EX
2-60	50444610	Switch, Slide	EX

11-3. FRONT PANEL

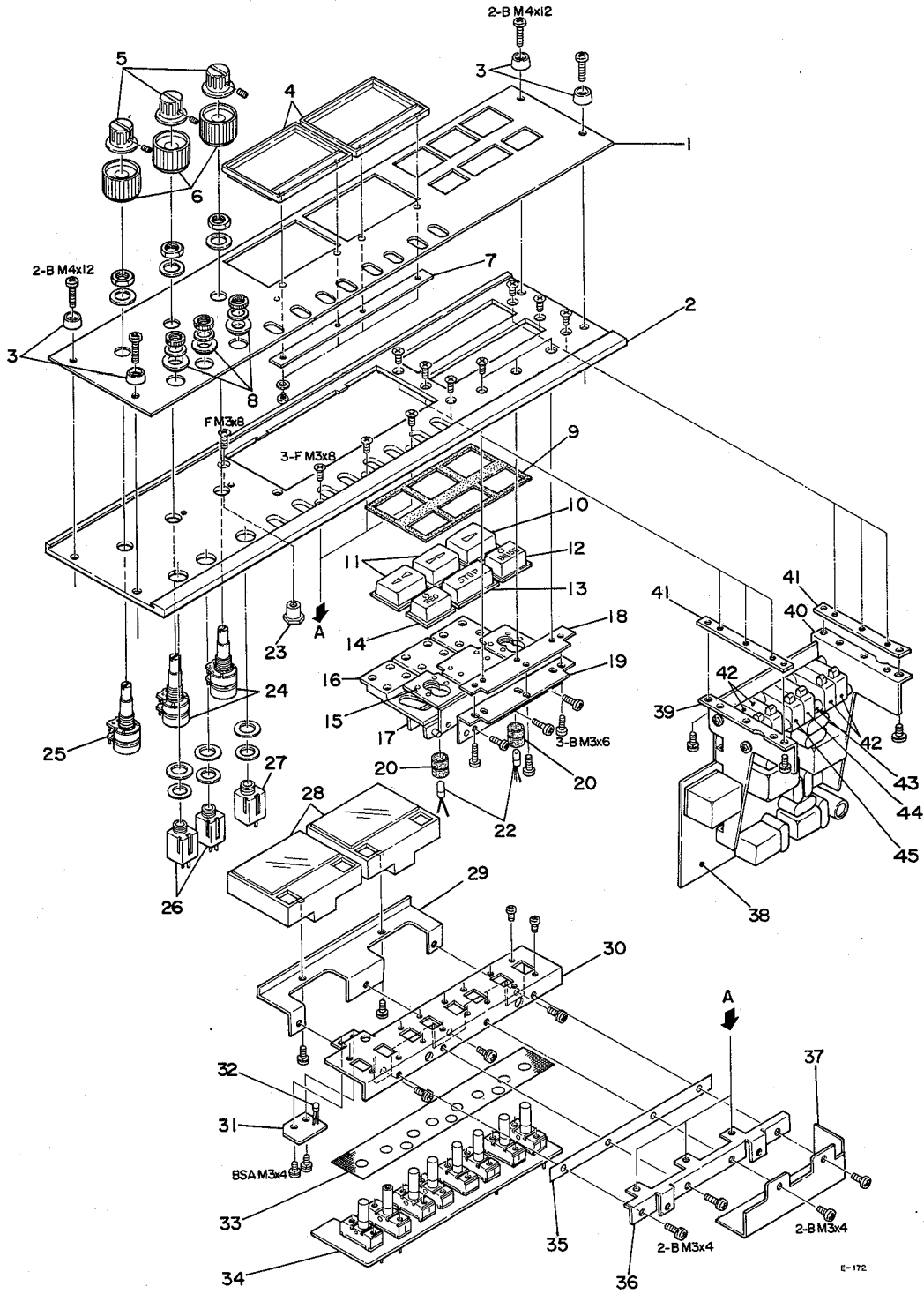

E-172

REF.NO.	PARTS NO.	DESCRIPTION	REMARKS
3- 1	55520490	Panel, Ampl. Trim	
3- 2	55520510	Panel, Ampl.	
3- 3	50277111	Washer, Trim	
3- 4	55301340	Escutcheon, VU Meter	
3- 5	50253750	Knob, Upper	
3- 6	55040590	Knob, Lower	
3- 7	55542650	Spacer, Escutcheon	
3- 8	50332650	Washer, Insul.	
3- 9	50237300	Rubber Protector, P	
3-10	50237201	Button, A	
3-11	50237211	Button, B	
3-12	50237262	Button Assy, PAUSE	
3-13	50237221	Button, STOP	
3-14	50237233	Button Assy, REC	
3-15	55340430	Hinge, A	
3-16	55340440	Hinge, B	
3-17	50237291	Plate Nut, PC Board	
3-18	55505210	Plate Nut, Hinge	
3-19	55505200	Bracket, Hinge; S	
3-20	50237490	Cushion, Lamp	
3-21		(not used)	
3-22	50414630	Lamp, Subminiature	
3-23	50331430	Shaft, Panel Attaching	
3-34	51500090	Var. Res., 50k Ω -A	
3-25	51500080	Var. Res., 250k Ω -A	
3-26	50430240	Jack, Phone; Single	
3-27	50432450	Jack, Phone; 3 cond.	
3-28	51650170	VU Meter	
3-29	55530400	Bracket, Meter	
3-30	55520541	Plate, Switch	
3-31	51671880	PC Board, LED	
3-32	51430480	LED, SLP-618B (Orange)	
3-33	55542660	Mask, Lever Switch	
3-34	51681850	PC Bd. Assy, Switch Mounting	
3-35	55542850	Plate, Lever Switch Spacer	
3-36	55530390	Angle, Bottom	
3-37	55542710	Plate, Shield	
3-38	51680652	PC Bd. Assy, Control	
3-39	50237131	Plate, Switch; Left	
3-40	50237141	Plate, Switch; Right	
3-41	50237121	Plate	
3-42	50446580	Switch, Micro; VV-15-3A	
3-43	50237160	Spacer	
3-44	50446570	Switch, Micro; VV-15-2A	
3-45	50446560	Switch, Micro; VV-15-1A	

11-4. REAR PANEL

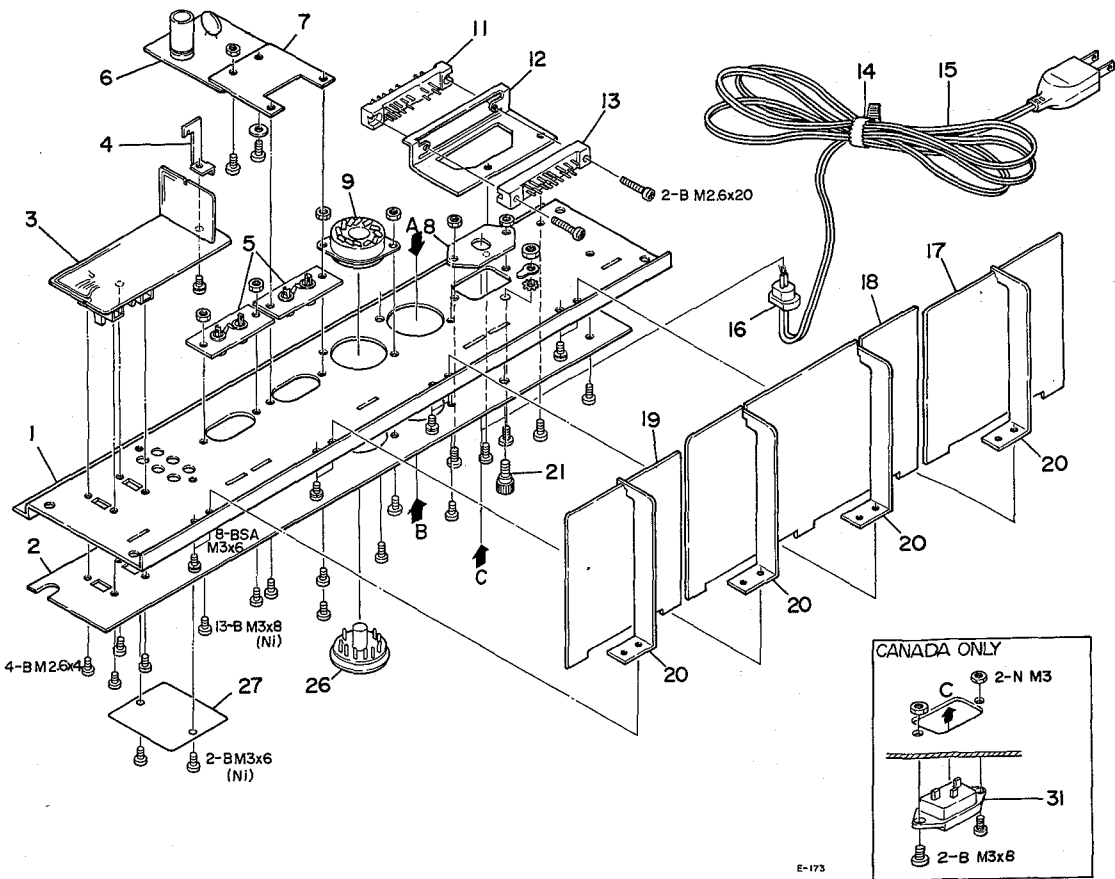
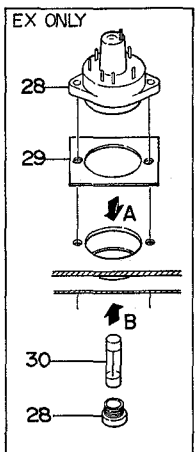
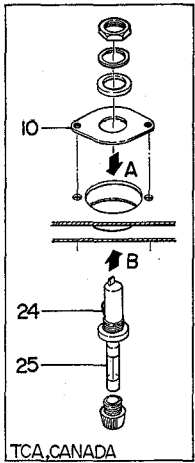

REF.NO.	PARTS NO.	DESCRIPTION	REMARKS
4- 1	55520520	Chassis, Ampl.	
4- 2	55520530	Panel, Rear Trim	
4- 3	51681860	PC Bd. Assy, Rear Panel	
4- 4	55542700	Bracket, PC Board Retaining	
4- 5	50434632	Jack, Pin; 2P	
4- 6	51681960	PC Bd. Assy, Muting	
4- 7	50237020	Plate, PC Board Holder	
4- 8	55541540	Strain Relief, Holder	EX, TCA
4- 9	50432700	Socket, 11P	
4-10	55542670	Adaptor, Fuse Holder	TCA, CANADA
4-11	50436520	Connector, 15P (Plug)	TCA, CANADA
	50436530	Connector, 15P (Plug)	EX
4-12	50237450	Bracket, Connector	
4-13	50438300	Connector, 15P (Socket)	TCA, CANADA
	50438310	Connector, 15P (Socket)	EX
4-14	50271770	Strap, Binding	
4-15	50471661	Cord, AC Power	TCA
	50471652	Cord, AC Power	EX
4-16	55300470	Strain Relief, AC Power Cord	EX, TCA
4-17	51681821	PC Bd. Assy, Ampl. B-Circuit	
4-18	51681830	PC Bd. Assy, Dolby "B" Processor	
4-19	51681810	PC Bd. Assy, Ampl. A-Circuit	
4-20	50233760	Plate, PC Board	
4-21	50454071	Post, Grounding	
4-22		(not used)	
4-23		(not used)	
4-24	50412280	Fuse Holder	TCA, CANADA
4-25	50411440	Fuse, 2A-250V	TCA, CANADA
4-26	50433010	Dummy Plug	
4-27	55542680	Caution Seal	
4-28	50435030	Voltage Selector, w/Fuse	EX
4-29	55501500	Mask, Fuse	EX
4-30	50411140	Fuse, 2A	EX 100V/117V area
	50411010	Fuse, 1A	EX 220V/240V area
4-31	51240140	Socket, AC	CANADA

INCLUDED ACCESSORIES

REF.NO.	PARTS NO.	DESCRIPTION	REMARKS
	51280010	Input-output Connection Cords, X2	
	*RE-702	Empty Reel, 7 in. Small Hub	
	57100300	Cleaning Stick (TZ-275)	
	50291350	Silicone Cloth	
	50411010	Fuse, 1A	EX 220V/240V area
	50411140	Fuse, 2A	EX 100V/117V area
	50411440	Fuse, 2A-250V	TCA, CANADA
	50291860	Oil and Applicator	
	50276971	Rubber Feet (for Horizontal Use), X4	
	50629620	Splicing Tape	
	51280120	AC Power Cord	CANADA
	51013440	A-2300SD Owner's Manual	EX
	51013430	A-2300SD Owner's Manual	TCA, CANADA
	51013371	Information Supplement	

NOTE: The Empty Reel is available as an Optional Accessory and thus is not assigned a special TEAC Parts number. Please order this by the MODEL CODE NUMBER (RE-702). This number is included on the package.

12. PC BOARD SECTION (Diagram)

12-1. AMPLIFIER A-CIRCUIT

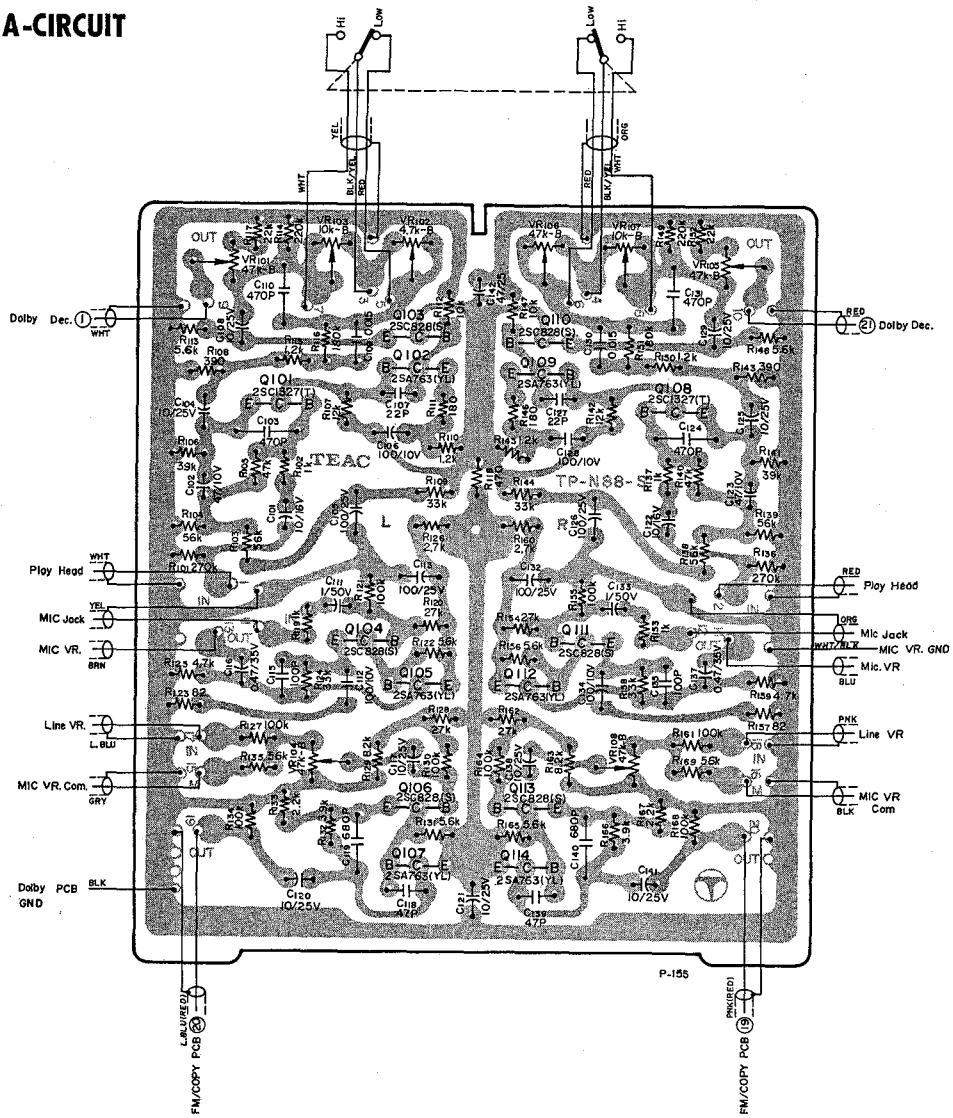

12-2. CONTROL RELAY

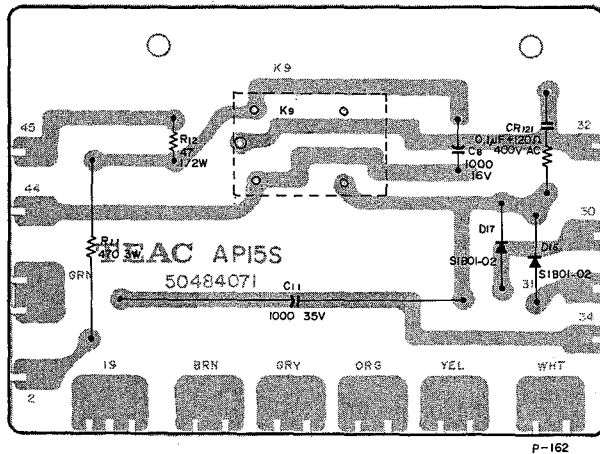

12-3. AMPLIFIER B-CIRCUIT

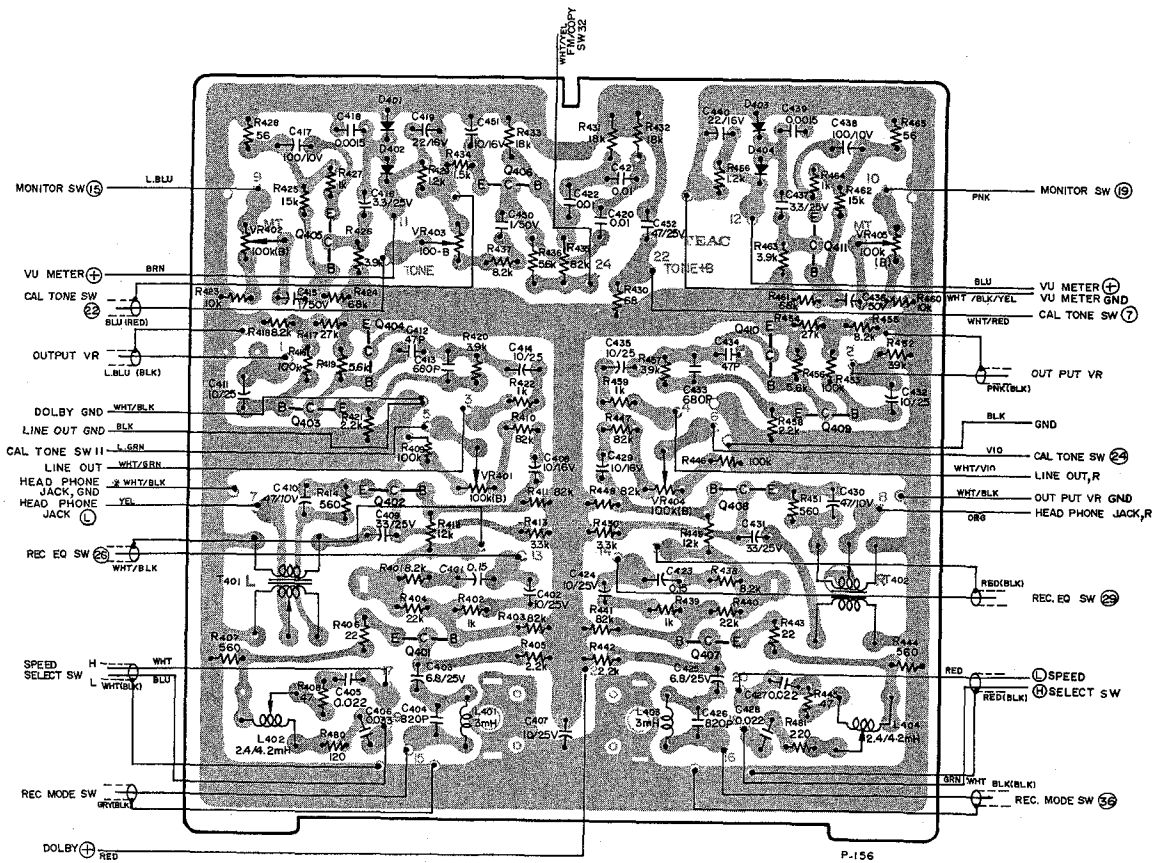

12-4. REAR PANEL PC BOARD

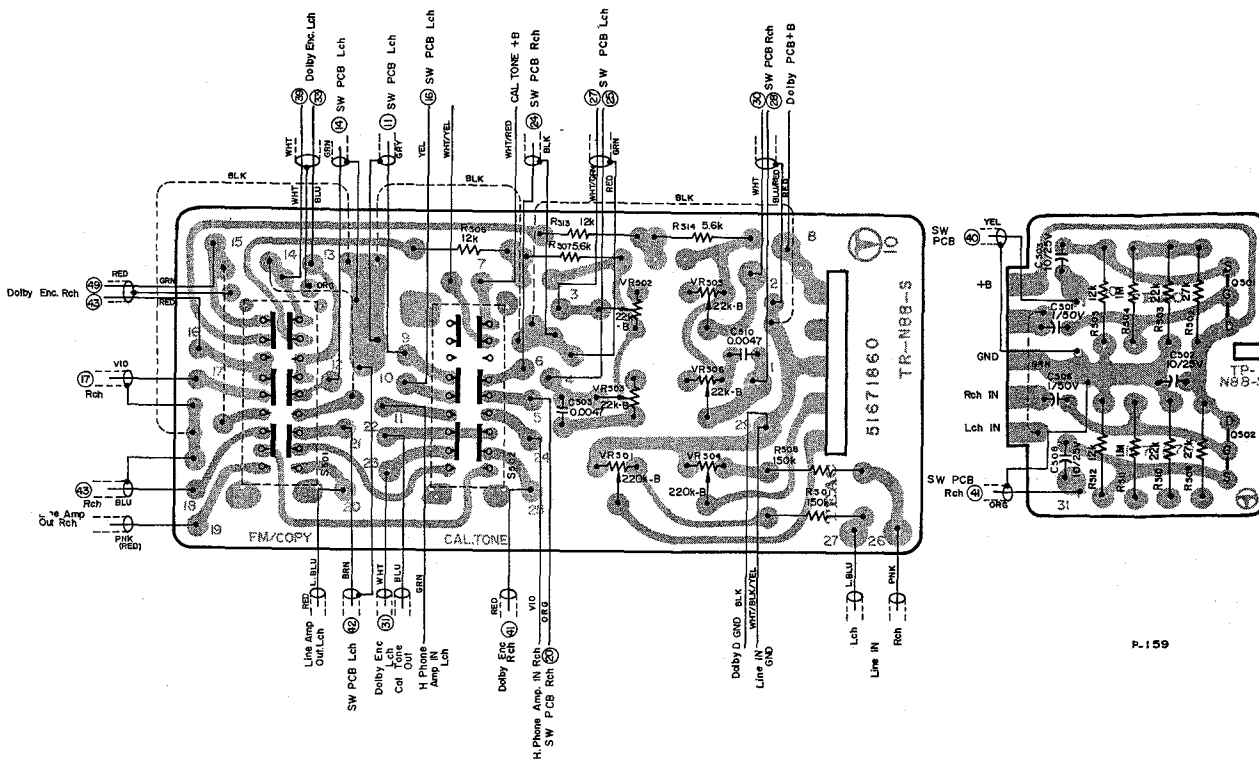

12-5. DOLBY "B" PROCESSOR

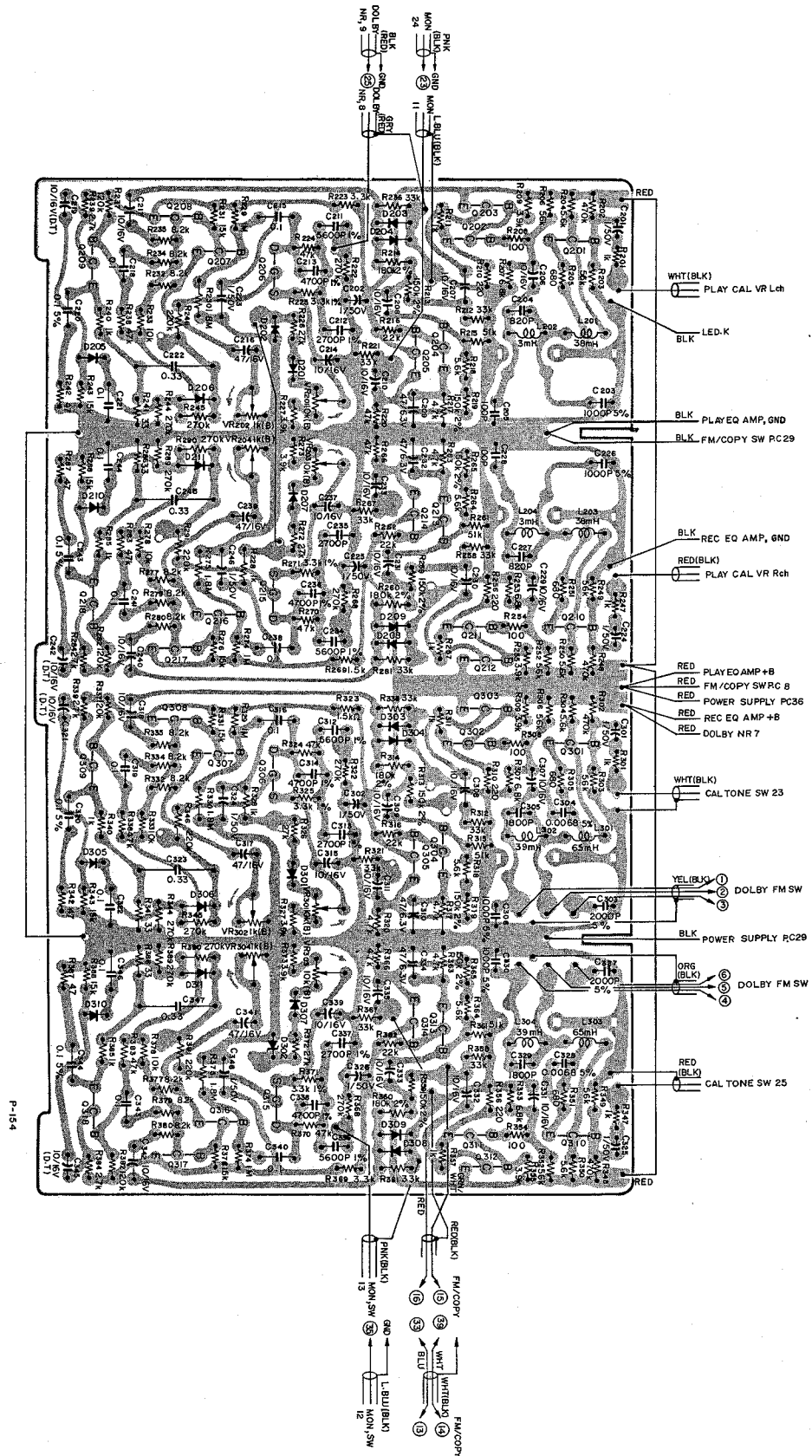

P-154

12-6. BIAS OSCILLATOR

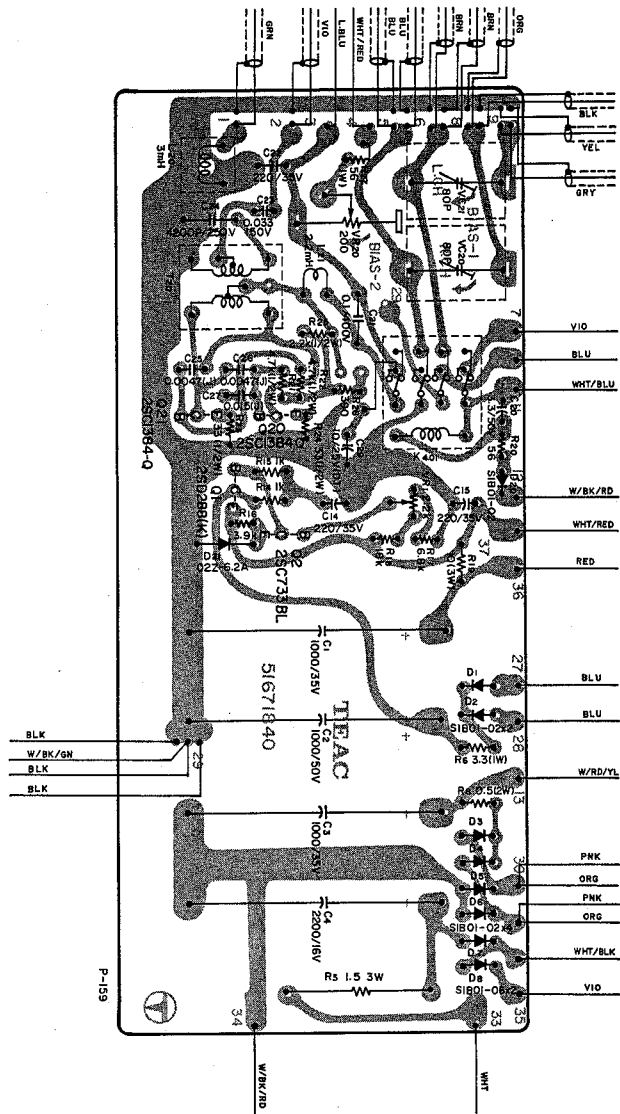

12-7. MUTING PC BOARD

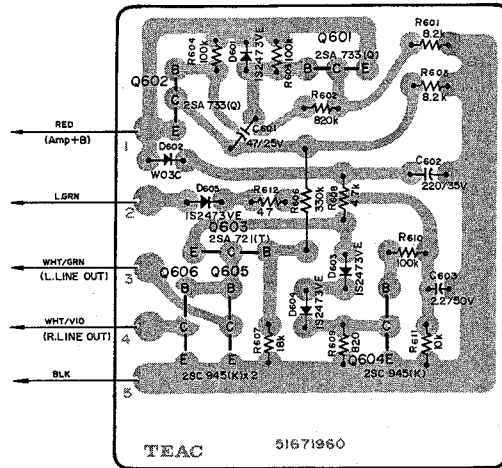

P-160

12-8. CONTROL PC BOARD

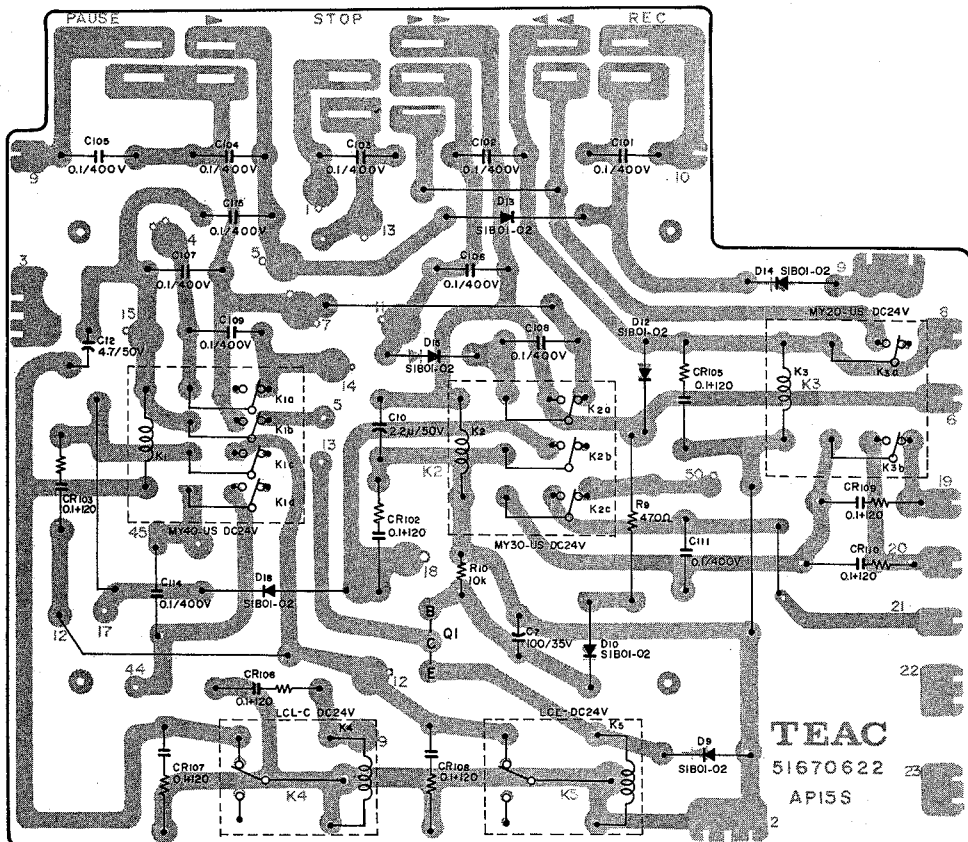

P-161

12-9. SW MOUNTING PC BOARD

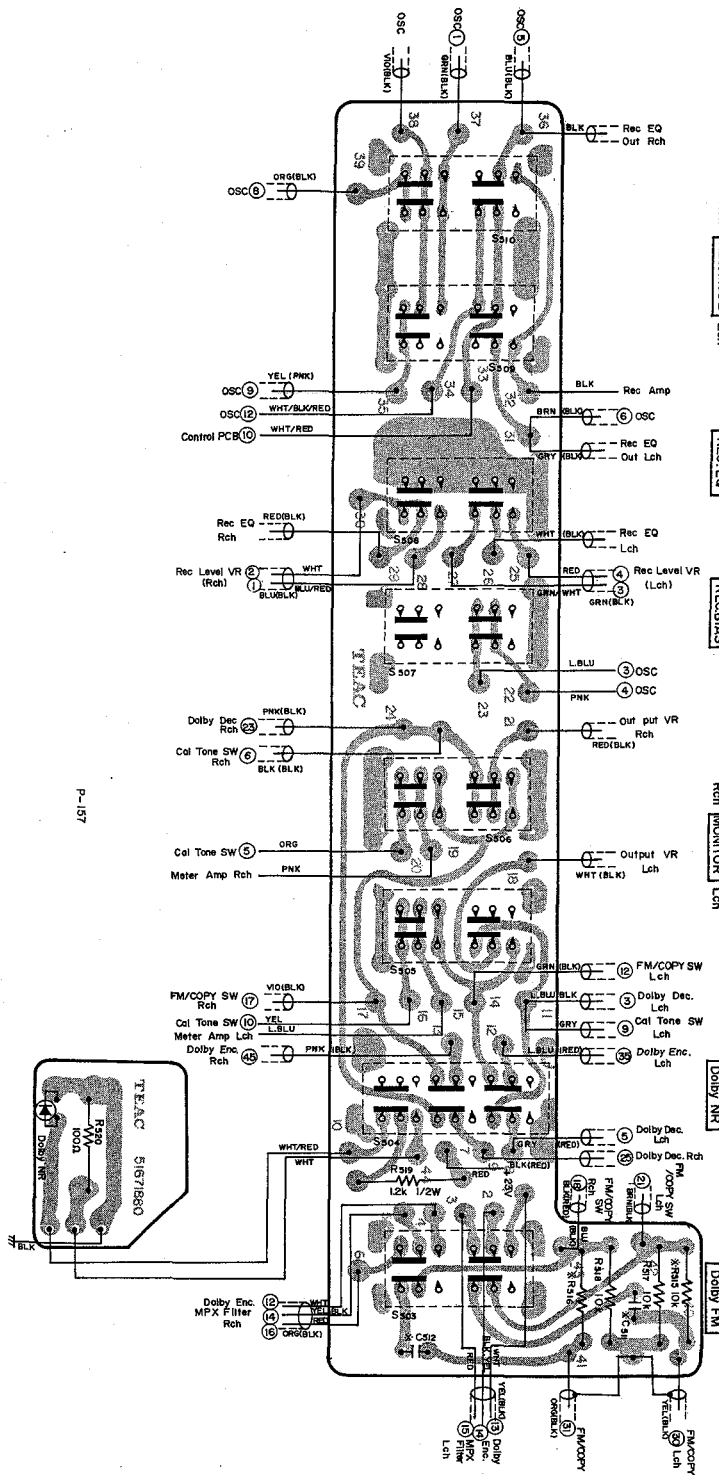

*:

	TCA/CAN	EX
C511-C512	0.0039μF/50V 5%	0.0056μF/50V 5%
R515-R516	18KΩ	8.2KΩ

12. PC BOARD SECTION (Parts List)

12-1. AMPLIFIER A-CIRCUIT

REF. NO.	PARTS NO.	DESCRIPTION
	51681810	PC Bd. Assy
	51671810	PC Board (only)

TRANSISTORS

Q101/Q108	50424610	2SC1327-T
Q102/Q109	50424870	23A763-YL (5)
Q103/Q110	50424600	2SC828-S
Q104/Q111	50424600	2SC828-S
Q105/Q112	50424870	2SA763-YL (5)
Q106/Q113	50424600	2SC828-S
Q107/Q114	50424870	2SA763-YL (5)

CARBON RESISTORS

All resistors are rated $\pm 5\%$ tolerance and 1/4 watt

R101/R136	50571400	270k Ω
R102/R137	50570820	1k Ω
R103/R138	50571241	56k Ω (SG)
R104/R139	50571241	56k Ω
R105/R140	50571220	47k Ω
R106/R141	50571201	39k Ω (SG)
R107/R142	50571081	12k Ω (SG)
R108/R143	50570720	390 Ω
R109/R144	50571180	33k Ω
R110/R145	50570840	1.2k Ω
R111/R146	50570640	180 Ω
R112/R147	50571060	10k Ω
R113/R148	50571000	5.6k Ω
R114/R149	50571380	220k Ω
R115/R150	50570840	1.2k Ω
R116/R151	50571360	180k Ω
R117/R152	50571140	22k Ω
R118/	50570740	470 Ω
R119/R153	50570820	1k Ω
R120/R154	50571160	27k Ω
R121/R155	50571300	100k Ω
R122/R156	50571000	5.6k Ω
R123/R157	50570560	82 Ω
R124/R158	50571180	33k Ω
R125/R159	50570980	4.7k Ω
R126/R160	50570920	2.7k Ω
R127/R161	50571300	100k Ω
R128/R162	50571160	27k Ω
R129/R163	50571040	8.2k Ω
R130/R164	50571300	100k Ω
R131/R165	50571000	5.6k Ω
R132/R166	50570960	3.9k Ω
R133/R167	50570900	2.2k Ω
R134/R168	50571300	100k Ω
R135/R169	50571240	56k Ω

SEMI-FIXED RESISTORS

VR101/VR105	50533520	47k Ω -B
VR102/VR106	50533460	4.7k Ω -B
VR103/VR107	50533480	10k Ω -B
VR104/VR108	50533520	47k Ω -B

REF. NO.	PARTS NO.	DESCRIPTION
----------	-----------	-------------

CAPACITORS

C101/C122	51700090	Tant. 10 μ F 16V
C102/C123	50555540	Elec. 47 μ F 10V
C103/C124	50547560	Dip. Mica 470pF 50V
C104/C125	51700820	Elec. 10 μ F 25V (LR)
C105/C126	50549740	Elec. 100 μ F 25V (KU)
C106/C128	50554570	Elec. 100 μ F 10V
C107/C127	50543820	Dip. Mica 22pF 50V
C108/C129	51700820	Elec. 10 μ F 25V (LR)
C109/C130	50548420	Mylar 0.015 μ F 50V
C110/C131	50547560	Dip. Mica 470pF 50V
C111/C133	50554540	Elec. 1 μ F 50V
C112/C134	50554570	Elec. 100 μ F 10V
C113/C132	50554170	Elec. 100 μ F 25V
C114/C136		(not used)
C115/C135	50547440	Dip. Mica 100pF 50V
C116/C137	50546682	Dip. Tant. 0.47 μ F 35V
C117/C138	50554040	Elec. 10 μ F 25V
C118/C139	50547420	Dip. Mica 47pF 50V
C119/C140	50547470	Dip. Mica 680pF 50V
C120/C141	50554040	Elec. 10 μ F 25V
C121	50554040	Elec. 10 μ F 25V
C142	50554490	Elec. 47 μ F 25V

12-2. CONTROL RELAY

REF. NO.	PARTS NO.	DESCRIPTION
	50491582	PC Bd. Assy (TCA/CAN)
	50491680	PC Bd. Assy (EX)
	50484071	PC Board
K9	50611130	Relay, SPDT DC12V
D16. D17	50422560	Diode, SIB01-02.
R11	50527140	Metal Film 470 Ω 3W
R12	50526140	Wire Wound 47 Ω 1/2W
C8	50554890	Elec. 1000 μ F 16V
C11	50555110	Elec. 1000 μ F 35V
CR121	50529050	Spark Killer, 0.1 μ F+120 Ω 400VAC

12-3. AMPLIFIER B-CIRCUIT

REF. NO.	PARTS NO.	DESCRIPTION
	51681820	PC Bd. Assy
	51671820	PC Board (only)

TRANSISTORS

Q401/Q407	50424600	2SC828-S
Q402/Q408	50424600	2SC828-S

REF. NO.	PARTS NO.	DESCRIPTION
Q403/Q409	50424600	2SC828-S
Q404/Q410	50424870	2SA763-YL (5)
Q405/Q411	50424600	2SC828-S
Q406	50424600	2SC828-S

DIODES

D401/D403	50422130	1N60
D402/D404	50422130	1N60

CARBON RESISTORS

All resistors are rated $\pm 5\%$ tolerance and 1/4 watt

R401/R438	50571040	8.2k Ω
R402/R439	50570820	1k Ω
R403/R441	50571280	82k Ω
R404/R440	50571140	22 Ω
R405/R442	50570900	2.2k Ω
R406/R443	50570420	22 Ω
R407/R444	50570760	560 Ω
R408/R445	50570500	47 Ω
R409/R446	50571300	100k Ω
R410/R447	50571280	82k Ω
R411/R448	50571280	82k Ω
R412/R449	50571080	12k Ω
R413/R450	50570940	3.3k Ω
R414/R451	50570760	560 Ω
R415/R452	50571200	39k Ω
R416/R453	50571300	100k Ω
R417/R454	50571160	27k Ω
R418/R455	50571040	8.2k Ω
R419/R456	50571000	5.6k Ω
R420/R457	50570960	3.9k Ω
R421/R458	50570900	2.2k Ω
R422/R459	50570820	1k Ω
R423/R460	50571060	10k Ω
R424/R461	50571260	68k Ω
R425/R462	50571100	15k Ω
R426/R463	50570960	3.9k Ω
R427/R464	50570820	1k Ω
R428/R465	50570520	56k Ω
R429/R466	50570840	1.2k Ω
R430	50570540	68k Ω
R431-3	50571120	18k Ω
R434	50570860	1.5k Ω
R435	50571280	82k Ω
R436	50571000	5.6k Ω
R437	50571040	8.2k Ω
R480/R481	50572600	120 Ω

SEMI-FIXED RESISTORS

VR401/VR404	50533490	100k Ω -B
VR402/VR405	50533490	100k Ω -B
VR403	50534290	100 Ω -B

REF. NO.	PARTS NO.	DESCRIPTION
----------	-----------	-------------

CAPACITORS

C401/C423	50546651	Dip. Tant.	0.15 μ F	35V
C402/C424	50554040	Elec.	10 μ F	25V
C403/C425	50546622	Dip. Tant.	6.8 μ F	25V
C404/C426	50543440	Polyst.	820pF	50V
C405/C427	50548980	Mylar	0.022 μ F	50V 5%
C406/C428	50549000	Mylar	0.033 μ F	50V 5%
C407	50554040	Elec.	10 μ F	25V
C408/C429	50554050	Elec.	10 μ F	16V
C409/C431	50554480	Elec.	33 μ F	25V
C410/C430	50555540	Elec.	47 μ F	10V
C411/C432	50554040	Elec.	10 μ F	25V
C412/C434	50547420	Dip. Mica	47pF	50V
C413/C433	50547470	Dip. Mica	680pF	50V
C414/C435	50554040	Elec.	10 μ F	25V
C415/C436	50554540	Elec.	1 μ F	50V
C416/C437	50554220	Elec.	3.3 μ F	25V
C417/C438	50554570	Elec.	100 μ F	10V
C418/C439	51702140	Mylar	0.0015 μ F	50V
C419/C440	50554880	Elec.	22 μ F	16V
C420-422	50548020	Mylar	0.01 μ F	50V
C450	50554540	Elec.	1 μ F	50V
C451	50554050	Elec.	10 μ F	16V
C452	50554490	Elec.	47 μ F	25V

COILS/TRANSFORMERS

L401/L403	50566300	Coil, Trap 3mH
L402/L404	50566370	Coil, Record EQ 2.4/4.2mH
T401/T402	50562141	Transformer, Output 3k Ω :8 Ω

12-4. REAR PANEL PC BOARD

REF. NO.	PARTS NO.	DESCRIPTION
----------	-----------	-------------

	51681860	PC Bd. Assy
	51671860	PC Board, A (only)
	51671870	PC Board, B (only)
Q501/Q502	50423840	Transistor, FET; 2SK30A-Y
R501/R508	50573340	Carbon 150k Ω 1/4W 5%
R502/R509	50573160	Carbon 27k Ω 1/4W 5%
R503/R510	50573140	Carbon 22k Ω 1/4W 5%
R504/R511	50573540	Carbon 1M Ω 1/4W 5%
R505/R512	50573080	Carbon 12k Ω 1/4W 5%
R506/R513	50573080	Carbon 12k Ω 1/4W 5%
R507/R514	50573080	Carbon 5.6k Ω 1/4W 5%
VR501/VR504	51500810	Var. Res., 220k Ω -B
VR502/VR505	51500750	Var. Res., 22k Ω -B
VR503/VR506	51500750	Var. Res., 22k Ω -B
C501/C506	50554540	Elec. 1 μ F 50V
C502	50554040	Elec. 10 μ F 25V
C503/C508	50554040	Elec. 10 μ F 25V
C505/C510	50548130	Mylar 0.0047 μ F 50V
S501-S502	51310310	Switch, Slide, 6PDT

12-5. DOLBY "B" PROCESSOR

REF. NO.	PARTS NO.	DESCRIPTION
	51681830	PC Bd. Assy
	51671830	PC Board (only)
	57240420	Pin, F3 Type (10 Used)

DOLBY DECODER SECTION

TRANSISTORS

Q201/Q210	50423770	2SC644-T
Q202/Q211	50423770	2SC644-T
Q203/Q212	50424880	2SA763-WL
Q204/Q213	50423770	2SC644-T
Q205/Q214	50423770	2SC644-T
Q206/Q215	57240981	FET, 2SK30A DA
Q207/Q216	50423770	2SC644-T
Q208/Q217	50424870	2SA763-YL (5)
Q209/Q218	50423770	2SC644-T

DIODES

D201/D207	50422440	S3016-R
D202	50422640	Zener, 02Z7.5A
D203/D208	50422440	S3016-R
D204/D209	50422440	S3016-R
D205/D210	50422130	1N60
D206/D211	50422440	S3016-R

CARBON RESISTORS

All resistors are rated $\pm 5\%$ tolerance and 1/4 watt

R201/R247	50570820	1k Ω
R202/R248	50571460	470k Ω
R203/R249	50571240	56k Ω
R204/R250	50571000	5.6k Ω
R205/R251	50570780	680 Ω
R206/R252	50571240	56k Ω
R207/R253	50571020	6.8k Ω
R208/R254	50570580	100 Ω
R209/R255	50570960	39k Ω
R210/R256	50570660	220 Ω
R211/R257	50570820	1k Ω
R212/R258	50571180	33k Ω
R213/R259	51809340	150k Ω 2%
R214/R260	51809360	180k Ω 2%
R215/R261	50571230	51k Ω
R216/R262	50571140	22k Ω
R217/R263	50570980	4.7k Ω
R218/R264	50571000	5.6k Ω
R219/R265	51809340	150k Ω 2%
R220/R266	50570980	4.7k Ω
R221/R267	50571180	33k Ω
R222/R268	50571400	270k Ω
R223	50570940	3.3k Ω
R269	50570860	1.5k Ω
R224/R270	50571220	47k Ω
R225/R271	50529960	3.3k Ω 1/2W 1%

REF. NO.	PARTS NO.	DESCRIPTION
R226/R272	50571160	27k Ω
R227/R273	50570960	39k Ω
R228	50570820	1k Ω
R229/R274	50571540	1M Ω
R230/R275	50571590	1.8M Ω
R231/R276	50571100	15k Ω
R232/R277	50571040	8.2k Ω
R233/R278	50571060	10k Ω
R234/R279	50571040	8.2k Ω
R235/R280	50571040	8.2k Ω
R236/R281	50571180	33k Ω
R237/R282	50571320	120k Ω
R238/R283	50571220	47k Ω
R239/R284	50570920	2.7 Ω
R240/R285	50570820	1k Ω
R241/R286	50570460	33 Ω
R242/R287	50570500	47 Ω
R243/R288	50571100	15k Ω
R244/R289	50571400	270k Ω
R245/R290	50571400	270k Ω
R246/R291	50571380	220k Ω

SEMIFIXED RESISTORS

VR201/VR203	50533480	10k Ω -B
VR202/VR204	50533950	1k Ω -B

CAPACITORS

C201/C224	50554540	Elec.	1 μ F	50V
C202/C225	50554540	Elec.		
C203/C226	50543980	Polyst.	100pF	50V 5%
C204/C227	50543440	Polyst.	820pF	50V 10%
C205/C228	50543400	Polyst.	100pF	50V 10%
C206/C229	50554050	Elec.	10 μ F	16V
C207/C230	50554050	Elec.	10 μ F	16V
C208/C231	50554050	Elec.	10 μ F	16V
C209/C232	50554030	Elec.	47 μ F	6.3V
C210/C233	50554050	Elec.	10 μ F	16V
C211/C234	51700130	Mylar	0.0056 μ F	50V 1%
C212/C235	51700140	Mylar	0.0027 μ F	50V 1%
C213/C236	51700120	Mylar	0.0047 μ F	50V 1%
C214/C237	50554050	Elec.	10 μ F	16V
C215/C238	50548040	Mylar	0.1 μ F	50V 10%
C216/C239	50554010	Elec.	47 μ F	16V
C217/C240	50554050	Elec.	10 μ F	16V
C218/C241	50548040	Mylar	0.1 μ F	50V 10%
C219/C242	50546563	Dip. Tant.	10 μ F	16V
C220/C243	50549280	Mylar	0.1 μ F	50V 5%
C221/C244	50548040	Mylar	0.1 μ F	50V 10%
C222/C245	50548830	Metalized Mylar	0.33 μ F	50V 10%
C223/C246	50554540	Elec.	1 μ	50V

COILS

L201/L203	50566660	Choke, 38mH 5% (Fixed)
L202/L204	50566300	Choke, 3mH (Adjustable)

REF. NO. PARTS NO. DESCRIPTION

DOLBY ENCODER SECTION

TRANSISTORS

Q301/Q310	50423770	2SC644-T
Q302/Q311	50423770	2SC644-T
Q303/Q312	50424880	2SA763-WL
Q304/Q313	50423770	2SC644-T
Q305/Q314	50423770	2SC644-T
Q306/Q315	57240981	FET, 2SK30A DA
Q307/Q316	50423770	2SC644-T
Q308/Q317	50424870	2SA763-YL (5)
Q309/Q318	50423770	2SC644-T

DIODES

D301/D307	50422440	S3016-R
D302	50422640	Zener, 02Z7.5A
D303/D308	50422440	S3016-R
D304/D309	50422440	S3016-R
D305/D310	50422130	1N60
D306/D311	50422440	S3016-R

CARBON RESISTORS

All resistors are rated $\pm 5\%$ tolerance and 1/4 watt.

R301/R347	50570820	1k Ω
R302/R348	50571460	470k Ω
R303/R349	50571240	56k Ω
R304/R350	50571000	5.6k Ω
R305/R351	50570780	680 Ω
R306/R352	50571240	56k Ω
R307/R353	50571020	6.8k Ω
R308/R354	50570580	100 Ω
R309/R355	50570960	39k Ω
R310/R356	50570660	220 Ω
R311/R357	50570820	1k Ω
R312/R358	50571180	33k Ω
R313/R359	51809340	150k Ω 2%
R314/R360	51809360	180k Ω 2%
R315/R361	50571230	51k Ω
R316/R362	50571140	22k Ω
R317/R363	50570980	4.7k Ω
R318/R364	50571000	5.6k Ω
R319/R365	51809340	150k Ω 2%
R320/R366	50570980	4.7k Ω
R321/R367	50571180	33k Ω
R322/R368	50571400	270k Ω
R323	50570860	1.5k Ω
R369	50570940	3.3k Ω
R324/R370	50571220	47k Ω
R325/R371	50529960	3.3k Ω 1/2W 1%
R326/R372	50571160	27k Ω
R327/R373	50570960	39k Ω
R328	50570820	1k Ω

REF. NO. PARTS NO. DESCRIPTION

R329/R374	50571540	1M Ω
R330/R375	50571590	1.8M Ω
R331/R376	50571100	15k Ω
R332/R377	50571040	8.2k Ω
R333/R378	50571060	10k Ω
R334/R379	50571040	8.2k Ω
R335/R380	50571040	8.2k Ω
R336/R381	50571180	33k Ω
R337/R382	50571320	120k Ω
R338/R383	50571220	47k Ω
R339/R384	50570920	2.7 Ω
R340/R385	50570820	1k Ω
R341/R386	50570460	33 Ω
R342/R387	50570500	47 Ω
R343/R388	50571100	15k Ω
R344/R389	50571400	270k Ω
R345/R390	50571400	270k Ω
R346/R391	50571380	220k Ω

SEMIFIXED RESISTORS

VR301/VR303	50533480	10k Ω -B
VR302/VR304	50533960	1k Ω -B

CAPACITORS

C301/C325	50554540	Elec.	1 μ F	50V
C302/C326	50554540	Elec.	1 μ F	50V
C303/C327	50544070	Polyst.	2000pF	50V 5%
C304/C328	50548930	Mylar	0.0068 μ F	50V 5%
C305/C329	50543990	Polyst.	1800pF	50V 5%
C306/C330	50543980	Polyst.	1000pF	50V 5%
C307/C331	50554050	Elec.	10 μ F	16V
C308/C332	50554050	Elec.	10 μ F	16V
C309/C333	50554050	Elec.	10 μ F	16V
C310/C334	50554030	Elec.	47 μ F	6.3V
C311/C335	50554050	Elec.	10 μ F	16V
C312/C336	51700130	Mylar	0.0056 μ F	50V 1%
C313/C337	51700140	Mylar	0.0027 μ F	50V 1%
C314/C338	51700120	Mylar	0.0047 μ F	50V 1%
C315/C339	50554050	Elec.	10 μ F	16V
C316/C340	50548040	Mylar	0.1 μ F	50V 10%
C317/C341	50554010	Elec.	47 μ F	16V
C318/C342	50554050	Elec.	10 μ F	16V
C319/C343	50548040	Mylar	0.1 μ F	50V 10%
C320/C344	50549280	Mylar	0.1 μ F	50V 5%
C321/C345	50546563	Dip. Tant.	10 μ F	16V
C322/C346	50548040	Mylar	0.1 μ F	50V 10%
C323/C347	50548830	Metalized	0.33 μ F	50V 10%
		Mylar		
C324/C348	50554540	Elec.	1 μ F	50V

COILS

L301/L303	57244060	Choke, 65mH 5% (Fixed)
L302/L304	57244050	Choke, 39mH (Adjustable)

12-6. BIAS OSCILLATOR

REF. NO.	PARTS NO.	DESCRIPTION
	51681840	PC Bd. Assy
	51671840	PC Board (only)
TRANSISTORS		
Q1	50425270	2SD288-K
Q2	50424440	2SC733-BL
Q20 · Q21	50424750	2SC1384-Q
DIODES		
D1-6	50422560	S1B01-02
D7 · D8	50422570	S1B01-06
D20	50422560	S1B01-02
D21	50422580	Zener, 02Z-6.2A
RESISTORS		
R5	50520340	Cement 1.5Ω 3W
R6	50525440	Wire Wound 3.3Ω 1W
R8	50526150	Wire Wound 0.5Ω 2W
R14 · R15	50570820	Carbon 1kΩ 1/4W 5%
R16	50570960	Carbon 3.9kΩ 1/4W 5%
R17	50571020	Carbon 6.8kΩ 1/4W 5%
R18	50571120	Carbon 18kΩ 1/4W 5%
R19	50528010	Wire Wound 10Ω 3W
R20	50570520	Carbon 56Ω 1/4W 5%
R21 · R22	50574980	Carbon 4.7kΩ 1/2W 5%
R23 · R24	50574460	Carbon 33Ω 1/2W 5%
R25	50517860	Carbon 2.2kΩ 1/2W
R26	50570720	Carbon 390Ω 1/4W 5%
R27	50526390	Wire Wound 56Ω 1W
SEMI-FIXED RESISTORS		
VR1	50533640	2.2kΩ-B
VR20	50539020	200Ω-B
CAPACITORS		
C1 · C3	50555110	Elec. 1000μF 35V
C2	50555700	Elec. 1000μF 50V
C4	50555660	Elec. 2200μF 16V
C14 · C15	50554380	Elec. 220μF 35V
C20	50555730	Elec. 3.3μF 50V
C21	50549920	Mylar 0.1μF 400V
C22	50554380	Elec. 220μF 35V
C23	51700160	Mylar 0.033μF 150V
C24	50544040	Mylar 4200pF 250V 5%
C25 · C26	50548910	Mylar 0.0047μF 50V 5%
C27	50548870	Mylar 0.015μF 50V 5%
TRIMMER CAPACITORS		
VC20 · VC21	50547070	80pF Max.

REF. NO.	PARTS NO.	DESCRIPTION
COILS/TRANSFORMERS		
L20	50566581	Coil, Dummy Load; 3mH
L21	50566720	Fixed Inductor, 2,2mH
T20	50563550	Transformer; Oscillator
RELAY		
K401	50610690	4PDT, DC24V
MISCELLANEOUS		
	55541630	Insulating Sheet
	50332950	Insulating Tube
	50333040	Heat Sink (2 used)

12-7. MUTING PC BOARD

REF. NO.	PARTS NO.	DESCRIPTION
	51681960	PC Bd. Assy
	51671960	PC Board
Q601 · Q602	50425470	Transistor, 2SA733-Q
Q603	50424650	Transistor, 2SA721-T
Q604-606	50425220	Transistor, 2SC945-K
D601	50425170	Diode, Silicon; 1S2473VE
D602	51430890	Diode, Silicon; W03C
D603-605	50425170	Diode, Silicon; 1S2473VE
R601 · R605	50571040	Carbon 8.2kΩ 1/4W 5%
R602	50571520	Carbon 820kΩ 1/4W 5%
R603 · R604	50571300	Carbon 100kΩ 1/4W 5%
R606	50573420	Carbon 330kΩ 1/4W 5%
R607	50571120	Carbon 18kΩ 1/4W 5%
R608	50570980	Carbon 4.7kΩ 1/4W 5%
R609	50570560	Carbon 820Ω 1/4W 5%
R610	50571300	Carbon 100kΩ 1/4W 5%
R611	50571060	Carbon 10kΩ 1/4W 5%
R612	50570500	Carbon 47Ω 1/4W 5%
C601	50554490	Elec. 47μF 25V
C602	50554380	Elec. 220μF 35V
C603	50554980	Elec. 2.2μF 50V

TEAC TECHNICAL INFORMATION

A-2300SD SERVICE MANUAL REVISION NOTICE

NO. 755-003
DATE NOV 27, 1975

The following changes or corrections should be made to the information contained on the pages indicated in the chart below. Please amend the existing manuals to reflect these changes.

INCORRECT (Basic Manual) → CORRECT

Page 15

9-6 VU METER LEVEL SET

1. With controls set as described above:
 - a. Place the CAL TONE SW on the back panel to the IN position.
 - b. Adjust VR-402/405 for 0 VU reading on the VU Meter.
2. Change the CAL TONE SW to OFF position and adjust VR-401/404 for 0 VU reading on the VU Meter.

9-6 VU METER LEVEL SET

1. Place the MONITOR SW to the SOURCE position.
2. Place the CAL TONE SW (on the back panel) to the ON position.
3. Adjust VR-402/405 for 0 VU reading on the VU Meter.
4. Change the MONITOR SW to TAPE, CAL TONE SW to the OFF position.
5. Play the 400 Hz in Section 1 of the Test Tape.
6. If adjustment is required, adjust VR-401/404 for 0 VU reading on the meter.

page 17

9-15 BIAS TRAP ADJUSTMENT

1. Remove all input signals.
2. Set MONITOR switches to SOURCE and REC MODE switches to ON.
3. Set REC BIAS switch to #1 position.
4. Load TEAC YTT-8013 test tape on the unit.

9-15 BIAS TRAP ADJUSTMENT

1. Remove all input signals.
2. Load YTT-8013 Test Tape on the unit.
3. Set the switches as outlined below:
MONITOR → SOURCE REC BIAS → 1
REC MODE → ON
4. Depress the REC and PAUSE button.

page 12

- VOLTAGE CONVERSION -

Revised Fuse cap

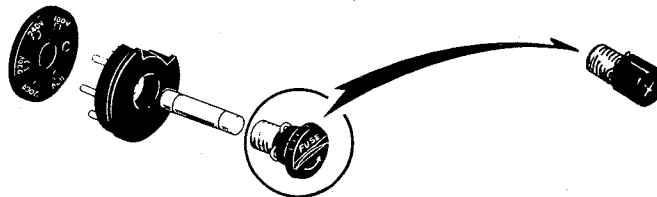

page 4

Inputs Microphone: 774 mV (-60 dB)/30k Ohms

Inputs Microphone: 0.774 mV (-60 dB)/30 k ohms

page 17

9-19 REC EQ #1 LEVEL SET

1. Thread a record Test Tape TEAC YTT-8003 on the unit.

9-19 REC EQ #1 LEVEL SET

1. Thread a record Test Tape YTT-8013 on the unit.

page 18

9-22 REC EQ #2 LEVEL SET

1. Thread a record Test Tape YTT-8003 on the unit.

9-22 REC EQ #2 LEVEL SET

1. Thread a record Test Tape YTT-8013 on the unit.

TEAC TECHNICAL INFORMATION

A-2300SD SERVICE MANUAL REVISION NOTICE

APPLICABLE SERIAL NO 303731 and up
NO. 755-002
DATE NOV 27, 1975

The following modifications have been made to the MUTING CIRCUIT of the A-2300SD with serial numbers 303731 and up. Please amend the existing manuals to reflect these changes.

REVISED MUTING CIRCUIT PC BOARD and PARTS LIST
See page 36 and 42 on Basic manual

ORIGINAL → REVISED

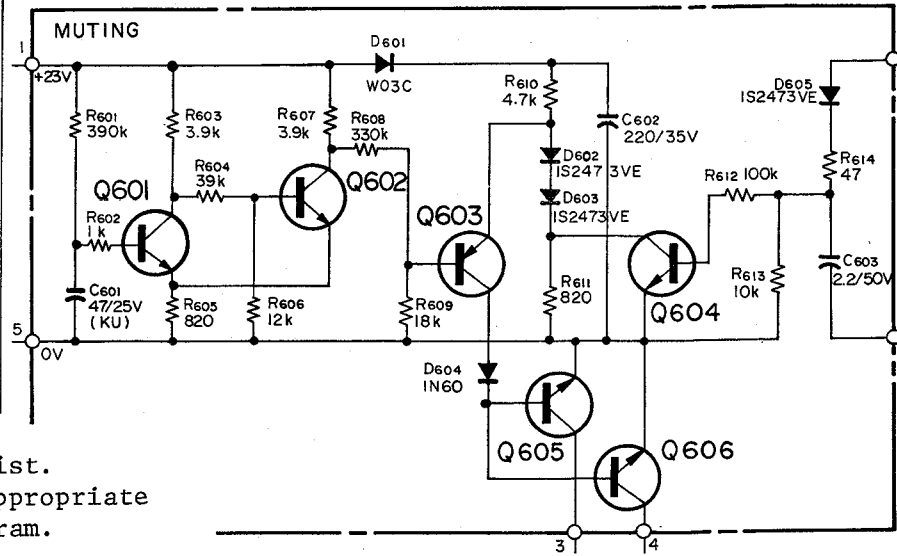
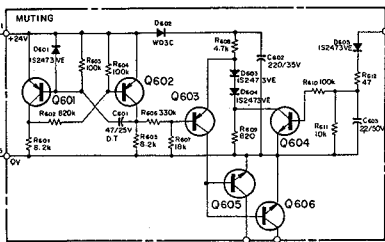

Below is revised parts list. For reference, see the appropriate Schematic and PC Bd. Diagram.

51681960 PC Bd. ASS'Y → 51681961 PC Bd. ASS'Y
51671960 PC Board → 51671960 PC Board

REF. NO.	PARTS NO.	DESCRIPTION
Q601,602	50424600	2SC828 (S)
D601	51430890	W03C
D602	50425170	1S2473VE
D603	50425170	1S2473VE
D604	50422170	1N60 (Germanium)
D605	50425170	1S2473VE
R601	50571440	390 k ohm
R602	50570820	1 k ohm
R603	50570960	3.9 k ohm
R604	50571200	39 k ohm
R605	50570560	820 ohm
R606	50571080	12 k ohm
R607	50570960	3.9 k ohm
R608	50573420	330 k ohm
R609	50571120	18 k ohm
R610	50570980	4.7 k ohm
R611	50570560	820 ohm
R612	50571300	100 k ohm
R613	50571060	10 k ohm
R614	50570500	47 ohm
C601	50554490	47µF
C602	50554380	220µF
C603	50554980	2.2µF

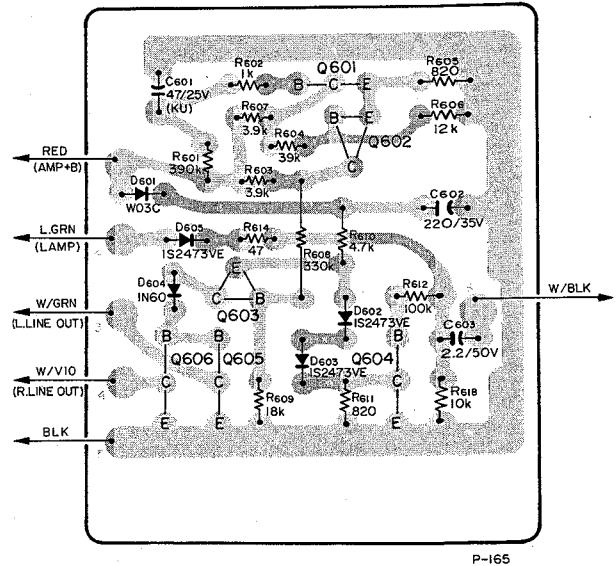

Revised Muting PC Board

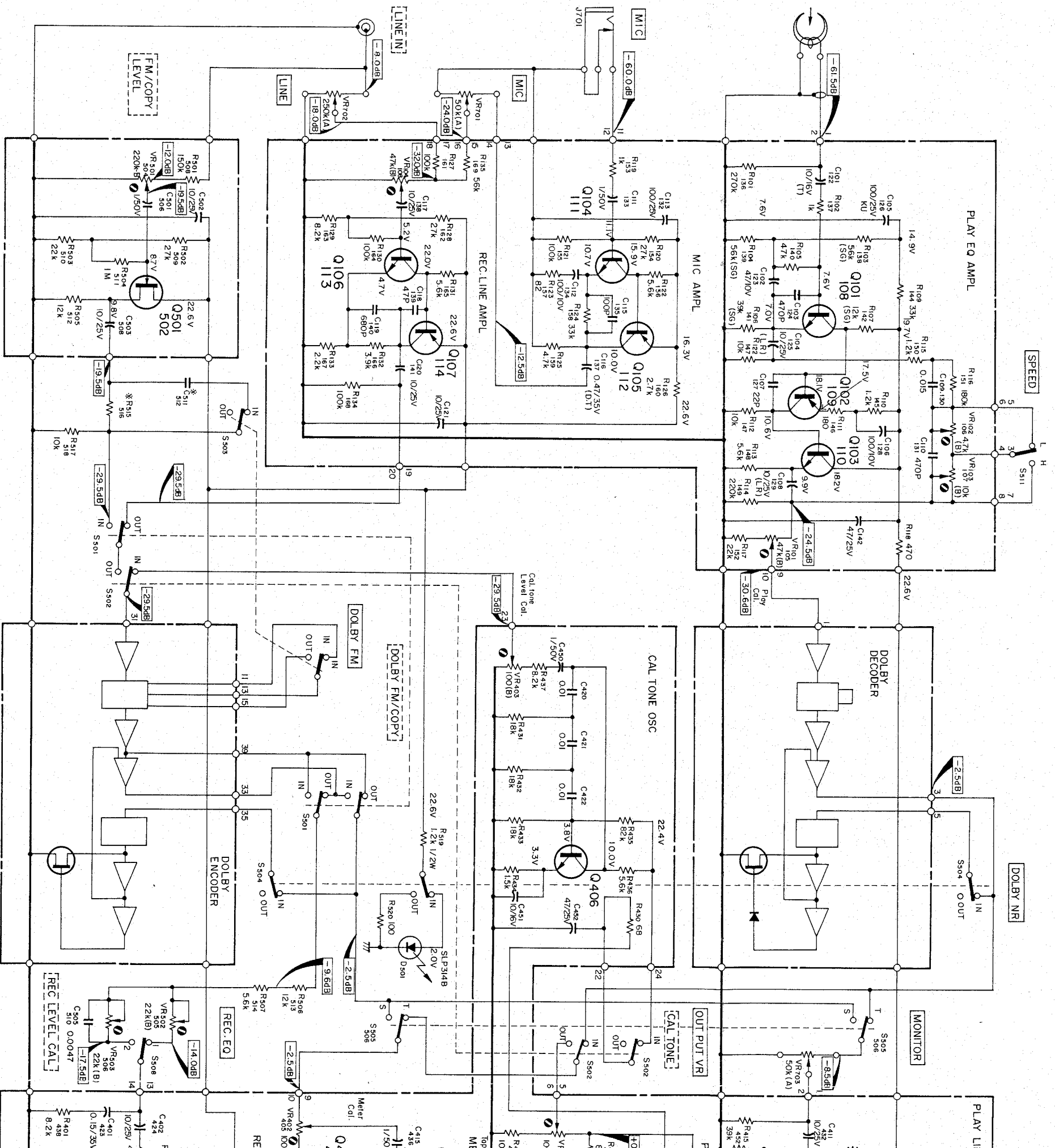

NOTES
 Schematic diagram Shown in PLAYBACK mode at 9.5 cm/s tape speed.
 Unless otherwise specified:
 All resistors values in ohms 1/4 watt k=1000 ohms.
 All capacitors values in micro farads
 Ⓢ Screwdriver adjustment
 □ : on front panel.
 □ : on rear panel.

REF. NO.	DESCRIPTION
Q101/Q108	2SC1327(T)
Q102/Q109	2SA763(YL) 5
Q103/Q110	2SC828(S)
Q104/Q111	2SC828(S)
Q105/Q112	2SA763(YL) 5
Q106/Q113	2SC828(S)
Q107/Q114	2SA763(YL) 5
Q501/Q502	2SK30A(Y)
Q401/Q407	2SC828(S)
Q402/Q408	2SC828(S)
Q403/Q409	2SC828(S)
Q404/Q410	2SA763(YL) 5
Q405/Q411	2SC828(S)
Q406	2SC828(S)
Q20/Q21	2SC1384(O)
Q601	2SA733(Q)
Q602	2SA733(Q)
Q603	2SA721(T)
Q604	2SC945(K)
Q605	2SC945(K)
Q606	2SC945(K)

REF. NO.	EX	TCA
R515/R516	8.2kΩ	18kΩ
C511/C512	0.0058μF	0.0039μF

NOTES
 Circuit DC voltage obtained with high input impedance
 DC voltage readings were obtained under the follow
 INPUT SIGNAL: NONE
 MODE : STEREO RECORD
 Circuit Signal Level obtained with high input impedance
 Reading in db reference to 0.775V.
 Signal level readings were obtained under the follow
 SIGNAL : 400Hz
 LINE CONTROL : REFERENCE LEVEL
 OUTPUT CONTROL : REFERENCE LEVEL

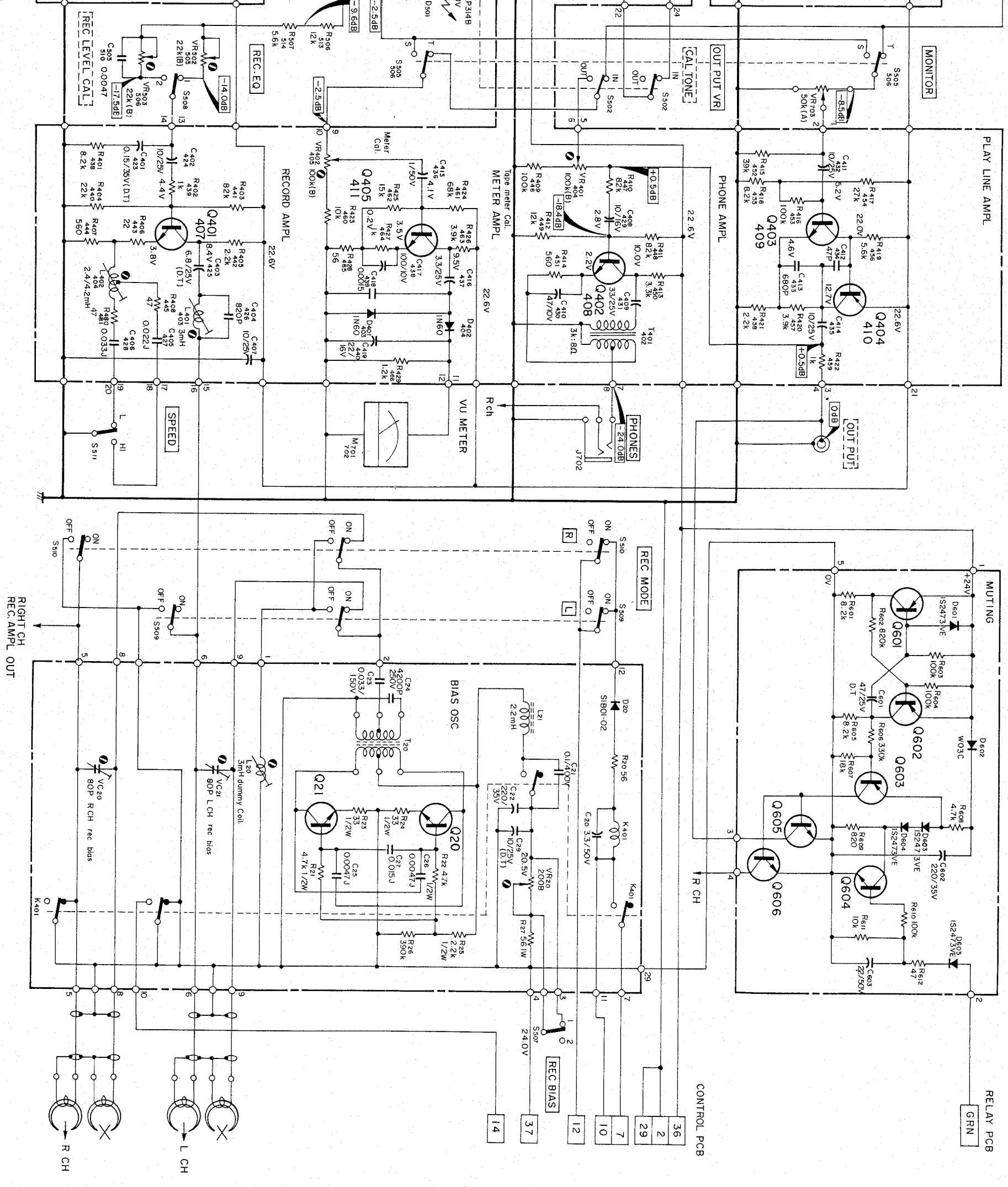

obtains with high input impedance DC VTVM.
 s were obtained under the following conditions.
 NONE
 STEREO RECORD
 obtain with high input impedance AC VTVM.
 ence to 0.775V.
 g were obtained under the following conditions.

REVISION	DATE	CHANGE NO.
1	07-75	
2		
3		
4		
5		
6		

PREAMPLIFIER
 MODEL NO. **A-2300SD**
 SHEET NO. **1**
TEAC CORPORATION

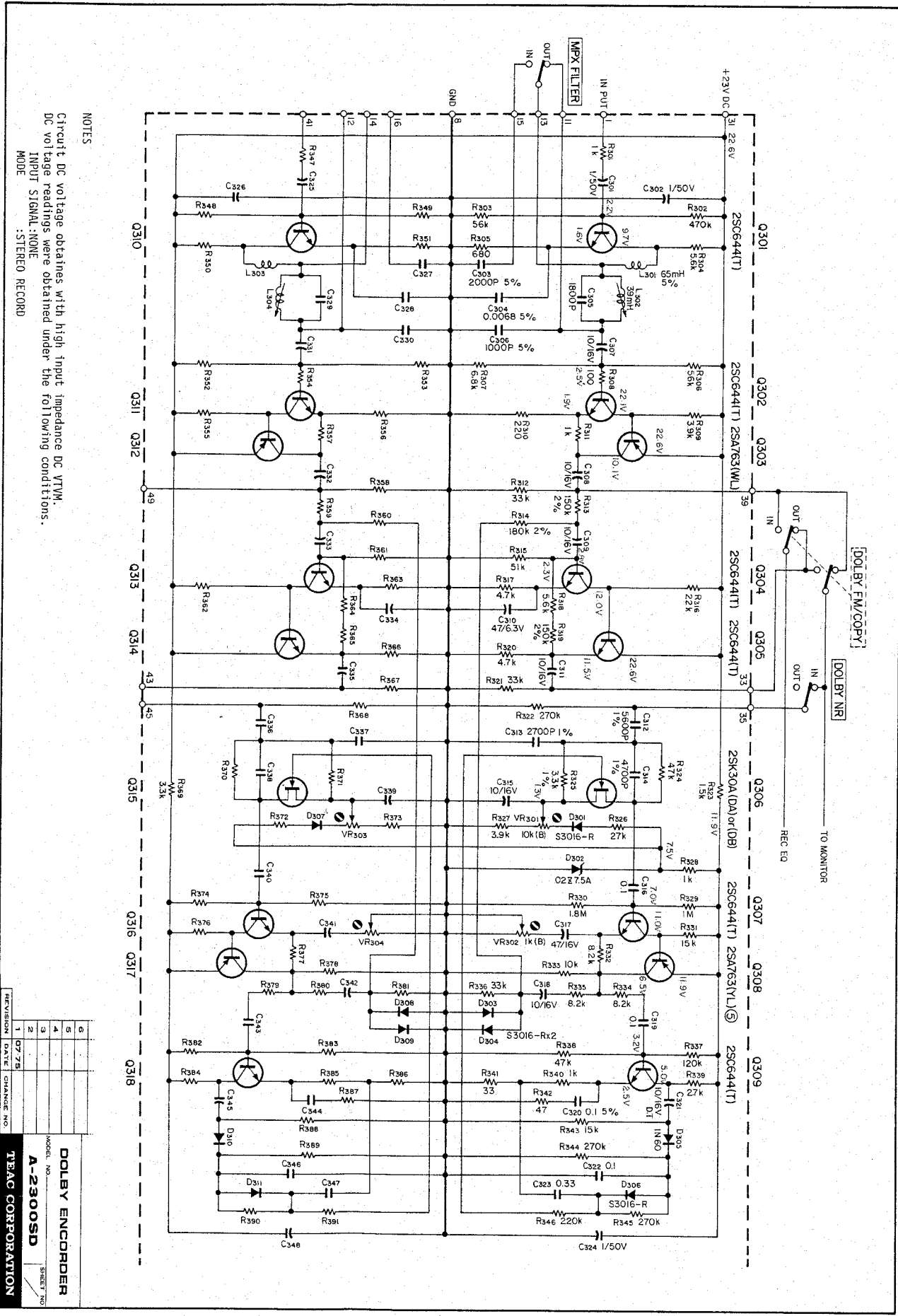

NOTES
 Circuit DC voltage obtained with high input impedance DC VTVM.
 DC voltage readings were obtained under the following conditions.
 INPUT SIGNAL: NONE
 MODE : STEREO RECORD

REVISION	DATE	CHANGE NO.
1	07/75	1

DOLBY ENCODER
 MODEL NO. **A-2300SD**
 SHEET NO. **1**
TEAC CORPORATION

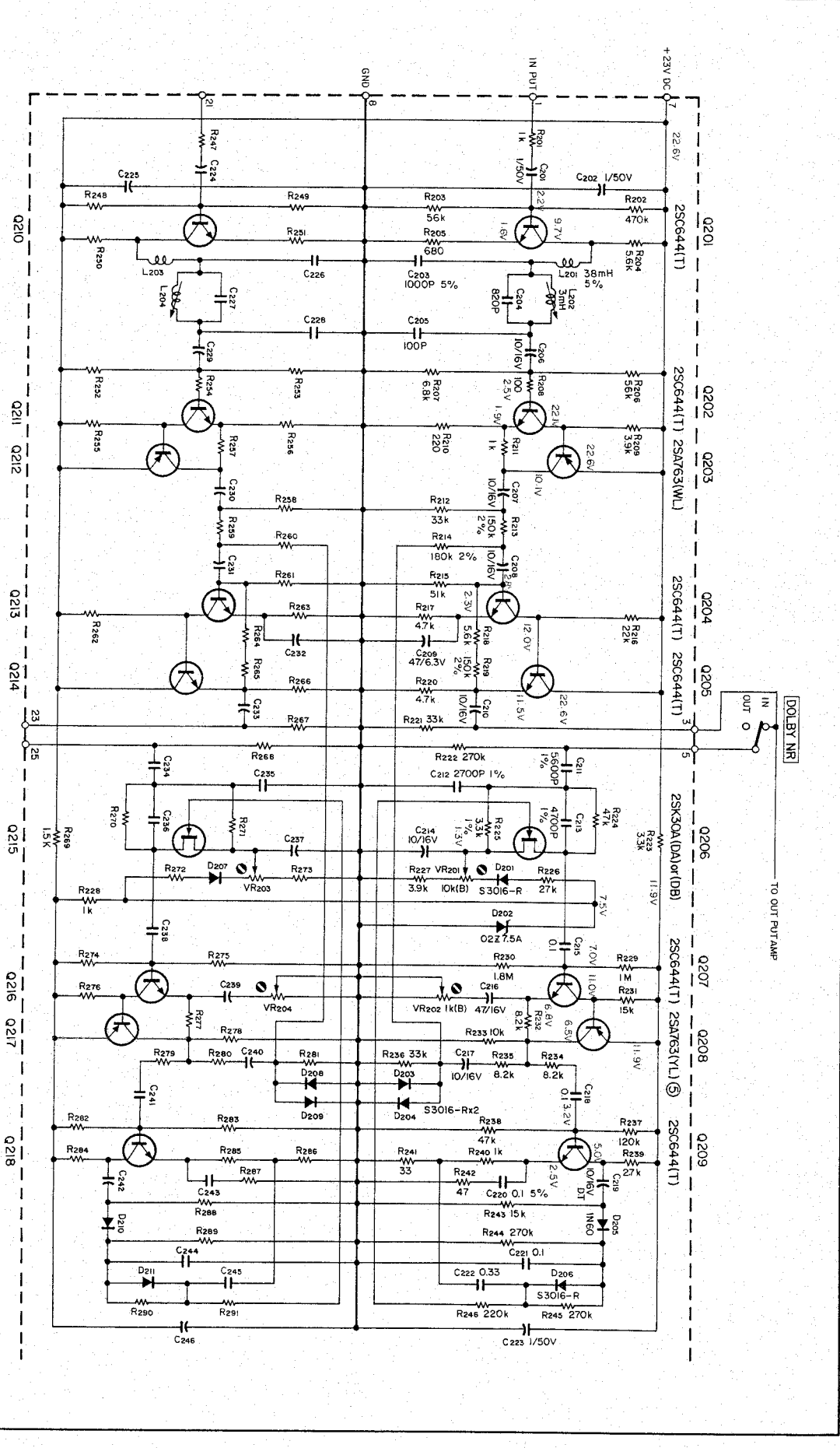

NOTES
 Circuit DC voltage obtained with high input impedance DC VTVM.
 DC voltage readings were obtained under the following conditions.
 INPUT SIGNAL: NONE
 MODE : STEREO RECORD

REVISION	DATE	CHANGE NO.
1	07/75	1

DOLBY DECODER
 MODEL NO. **A-2300SD**
 SHEET NO. **1**
TEAC CORPORATION

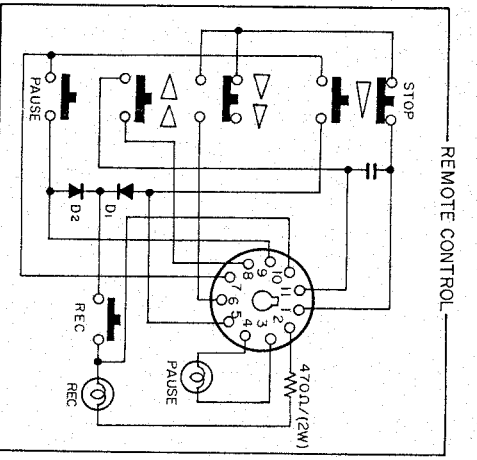
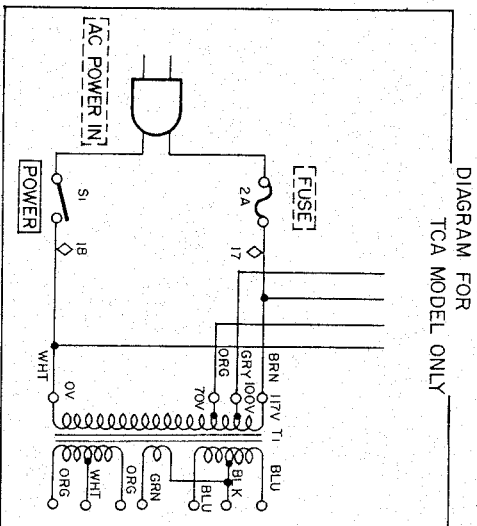
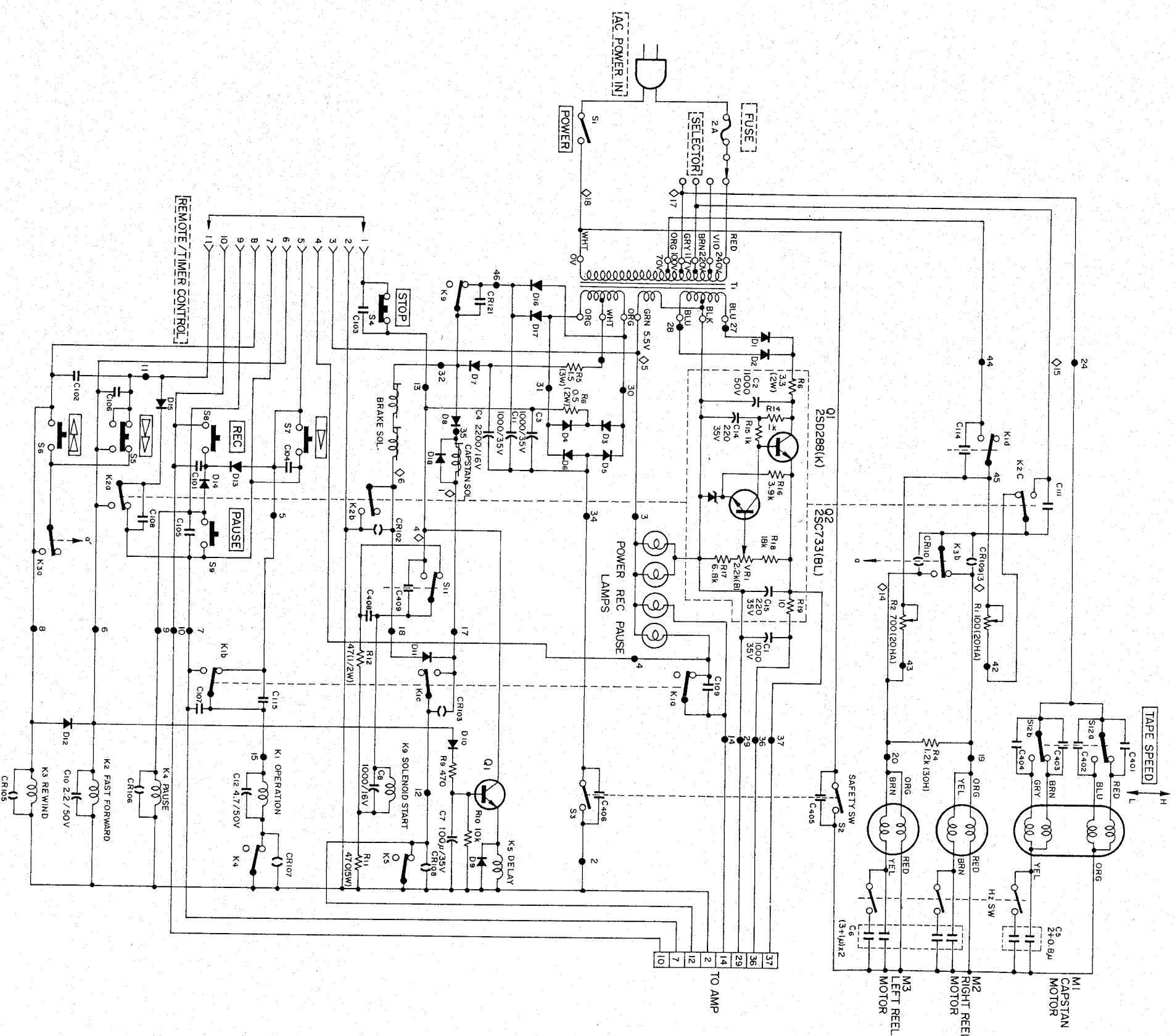

- NOTES**
- All relays shown not energized (stop mode)
 - TAPE SPEED switch shown in the HIGH position
 - Frequency conversion switch shown in the 60 Hz position (EX MODEL)
 - On front panel
 - On rear panel
 - Spark killer 0.1-120/400WV
 - Screwdriver adjustment
 - 0.1/400WV
 - D1~6, D9~14, D16~17: SIB01-02
 - D7, D8, D18: SIB01-06
 - ◇ : Board No.
 - ◊ : Connector No.

REVISION	DATE	CHANGE NO.
1	07/78	
2		
3		
4		
5		
6		

TAPE TRANSPORT
 MODEL NO. **A-2300SD**
 SHEET NO. **TEAC CORPORATION**

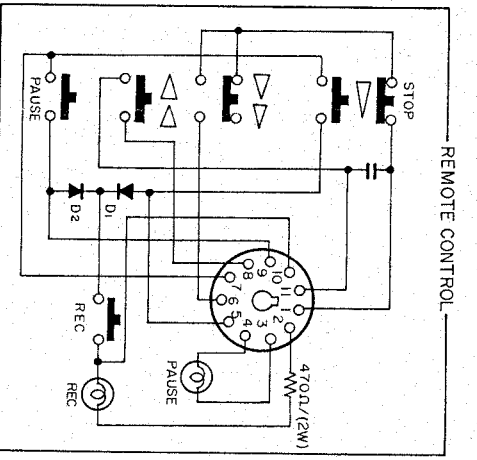
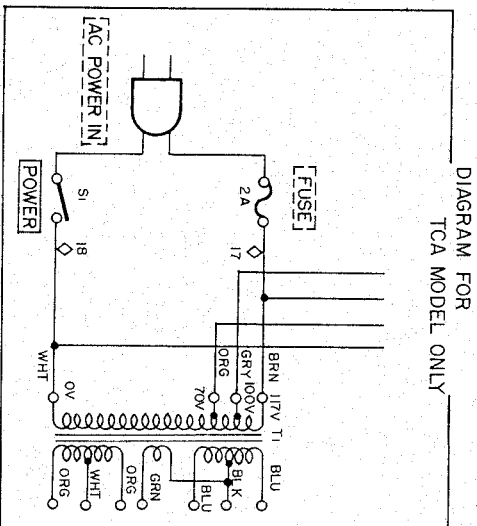
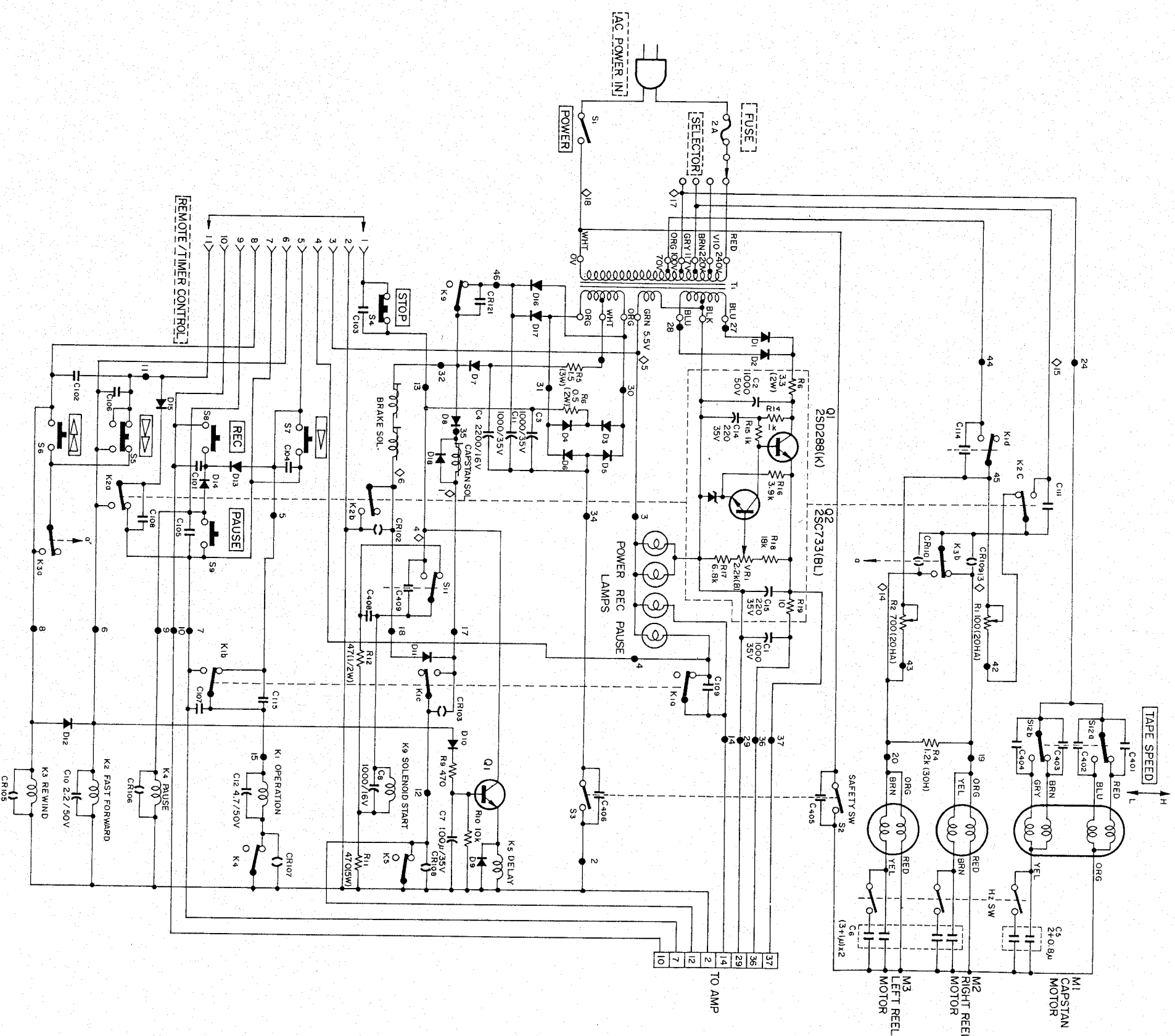

- NOTES**
- All relays shown not energized (stop mode)
 - TAPE SPEED switch shown in the HIGH position
 - Frequency conversion switch shown in the 60 Hz position (EX MODEL)
 - On front panel
 - On rear panel
 - Spark killer 0.1-120/400WV
 - Screwdriver adjustment
 - 0.1/400WV
 - D1~6, D9~14, D16~17: SIB01-02
 - D7, D8, D18: SIB01-06
 - Connector No.

REVISION	DATE	CHANGE NO.
1	07/78	
2		
3		
4		
5		
6		

TAPE TRANSPORT
 MODEL NO. **A-2300SD**
 SHEET NO. **TEAC CORPORATION**

12-8. CONTROL PC BOARD

REF. NO.	PARTS NO.	DESCRIPTION
	51680652	PC Bd. Assy
	51670622	PC Board (only)
Q1	50424620	Transistor, 2SD235-Y
K1	50611180	Relay, 4PDT DC 24V
K2	50611120	Relay, 3PDT DC 24V
K3	50611140	Relay, DPDT DC 24V
K4	50611200	Relay, SPDT DC 24V
K5	50611170	Relay, SPDT DC 24V
D9	50422560	Diode, SIB01-02
D12-15	50422560	Diode, SIB01-02
D18	50422560	Diode, SIB01-02
R9	50574740	Carbon 470 Ω 1/2W 5%
R10	50575060	Carbon 10k Ω 1/2W 5%
C7	50554630	Elec. 100 μ F 35V
C10	50554980	Elec. 2.2 μ F 50V
C12	51700080	Elec. 4.7 μ F 50V
C101-106	50549920	Metalized Mylar 0.1 μ F 400V AC
C107-109	50549920	Metalized Mylar 0.1 μ F 400V AC
C111	50549920	Metalized Mylar 0.1 μ F 400V AC
C114 · C115	50549920	Metalized Mylar 0.1 μ F 400V AC
CR102 · CR103	50529050	Spark Killer, 0.1 μ F +120 Ω 400WV
CR105-110	50529050	Spark Killer 0.1 μ F +120 Ω 400WV

12-9. SW MOUNTING PC BOARD

REF. NO.	PARTS NO.	DESCRIPTION
	51681850	PC Bd. Assy
	51671850	PC Board (only)
R515 · R516	50573040	Carbon 8.2k Ω 1/4W (EX)
	50573120	Carbon 18k Ω 1/4W(TCA/CAN)
R517 · R518	50573060	Carbon 10k Ω 1/4W
R519	50517870	Carbon 1.2k Ω 1/2W 5%
R520	50572580	Carbon 100 Ω 1/4W
C511 · C512	50548900	Mylar 0.0039 μ F 50V 5%(TCA/CAN)
	50548920	Mylar 0.0056 μ F 50V 5%(EX)
S503	51320080	Switch, Lever; 4PDT (Shorting)
S504	51320110	Switch, Lever; 6PDT (Non-shorting)
S505 · S506	51320100	Switch, Lever; 4PDT (Non-shorting)
S507-510	51320080	Switch, Lever; 4PDT (Shorting)